



Multi Air Conditioner

SVC MANUAL(Exploded View)

MODEL : L8UC150BFA1

CAUTION

Before Servicing the unit, read the safety precautions in General SVC manual.
Only for authorized service personnel.

1. Specification

| Outdoor Unit | | | L8UC150BFA1 |
|--|-------------------------------|-----------------------|--|
| Nominal Capacity (Min_Rating) | Cooling | kW | 5.28~43.96 |
| | | Btu/h | 18 000~15 0000 |
| | Heating | kW | - |
| | | Btu/h | - |
| Nominal Input (Min_Rating) | Cooling | kW | 3.5~17 |
| | Heating | kW | - |
| Testing Combination | | | LMNC182D3A0+LMNC242D3A0+LMNC182TEA0, LMNC242TFA0+LMNC302TFA0+LMNC362TDA0 |
| Running Current(Rating) | Cooling | A | 10.83 |
| | Heating | A | - |
| Starting Current | Cooling/Heating | A | - |
| Power Supply | | Ø / V / Hz | 3 /220 /60 |
| Power and Transmission Cable(Outdoor to Indoor or Outdoor to BD) | | No. x mm ² | 4 x 14(including earth) |
| Power and Transmission Cable (Outdoor to BD) | | No. x mm ² | 4 x 0.75(including earth) |
| Power and Transmission Cable(BD to Indoor) | | No. x mm ² | 4 x 0.75(including earth) |
| Dimensions | W x H x D | mm(inch) | 1 280*1 520*730 (50.4*59.8*28.7) |
| Net Weight | | kg(lbs) | 300(661) |
| Max. Number of Connectable Indoor Units | | | 8 |
| Compressor (#1) Constant speed (A+B+C) (MPS cycle 1) | Type | | Rotary |
| | Qty x Model | | 3 x QPT442RAA |
| | Motor type | | 3 Phase Induction |
| | Oil charge volume | cc | 1 200 |
| | Oil Type | | ATMOS M60/SUNISO 4GSI |
| Compressor (#2) Constant speed (D+E) (MPS cycle 2) | Type | | Rotary |
| | Qty x Model | | 2 x QPT442RAA |
| | Motor type | | 3 Phase Induction |
| | Oil charge volume | cc | 1 200 |
| | Oil type | | ATMOS M60/SUNISO 4GSI |
| Compressor (#3) | Type | | - |
| | Qty x Model | | - |
| | Motor type | | - |
| | Oil charge volume | cc | - |
| | Oil type | | - |
| Refrigerant | Cycle1(90k) Charge (at 7.5m) | g(oz) | 7 200(254) |
| | Cycle2(60k) Charge (at 7.5m) | g(oz) | 4 800(169) |
| | Type | | R22 |
| | Control | | EEV |
| Additional Refrigerant Charge (Based on Liquid pipe) | g/m(oz/ft) | | Ø6.35 : 20g/m |
| | | | Ø9.52 : 50g/m |
| | | | Ø12.7 : 120g/m |
| Heat Exchanger | (Rows x Column x FPI) x No. | | (2R x 14C x 17) x 2 |
| | | | (2R x 30C x 17) x 1 |
| | | | (3R x 30C x 17) x 1 |
| | | | - |
| Fan | Defrosting Method | | - |
| | Capacitor | µF/Vac | 10 / 370 |
| | Drive | | Direct Drive |
| | Discharge Direction(Side/Top) | | Top |
| Sound Level(H) | Air Flow RateA~No. of Fan | CMM(cfm) | 180 (6 357) |
| | Sound Pressure | dB(A)+3 | 60 |
| Piping Connections | Liquid(Cycle A) | mm(inch) | 12.7 (1/2) |
| | Gas(Cycle A) | mm(inch) | 25.4 (1) |
| | Liquid(Cycle B) | mm(inch) | 9.52 (3/8) |
| | Gas(Cycle B) | mm(inch) | 19.05 (3/4) |
| | High Pressure Gas | mm(inch) | - |
| Max. Interunit Piping Length | Total Piping | m | 110 |
| | Main Piping | m | 50 |
| | Total Branch Piping | m | 60 |
| | Each Branch Piping | m | 15 |
| Max. Elevation Difference | Outdoor Unit~Indoor Unit | m | 45 |
| | Indoor Unit~Indoor Unit | m | 10 |
| Operation Range (Outdoor) | Cooling | °C(°F) | 21~54 (69.8~129.2) |
| | Heating | °C(°F) | - |

Note :

- Capacities are based on the following conditions:
Cooling: - Indoor Temperature 27°C(80.6°F) DB/19°C(66.2°F) WB
- Outdoor Temperature 35°C(95°F) DB/24°C(75.2°F) WB
Heating: - Indoor Temperature 20°C(68°F) DB/15°C(59°F) WB
- Outdoor Temperature 7°C(44.6°F) DB/6°C(42.8°F) WB
Piping Length - Interconnecting Piping Length 7.5m
- Level Difference of Zero

- Wiring cable size must comply with the applicable local and national code.
- The specification may be subject to change without prior notice for purpose of improvement.

Conversion Formula

$$\text{kW} = \text{Btu/h} \times 0.0002931$$

$$\text{cfm} = \text{CMM} \times 35.3$$

2. List of Functions

| Category | Function | L8UC150BFA1 |
|------------------------|-----------------------------------|---|
| Reliability | Defrost / Deicing | X |
| | High pressure switch | O |
| | Low pressure switch | O |
| | Phase protection | O |
| | Restart delay (3-minutes) | O |
| | Self diagnosis | O |
| | Soft start | X |
| | Test function | X |
| | Convenience | Auto operation(Artificial intelligence) |
| Auto restart operation | | O |
| CAC network function | Network solution(LGAP) | O |
| | PDI(Power Distribution Indicator) | PQNUD1S00 |
| | PI485 | PMNFP14A0 |
| Special function kit | Low ambient operation | X |
| Others | Thermistor | - |

O : Applied X : Not applied - : No relation

Option : Model name & price are different according to options, and assembled in factory with main unit.

Accessory : Installed at field, ordered and purchased separately by the corresponding model name, supplied with separate package

3. Piping Diagrams

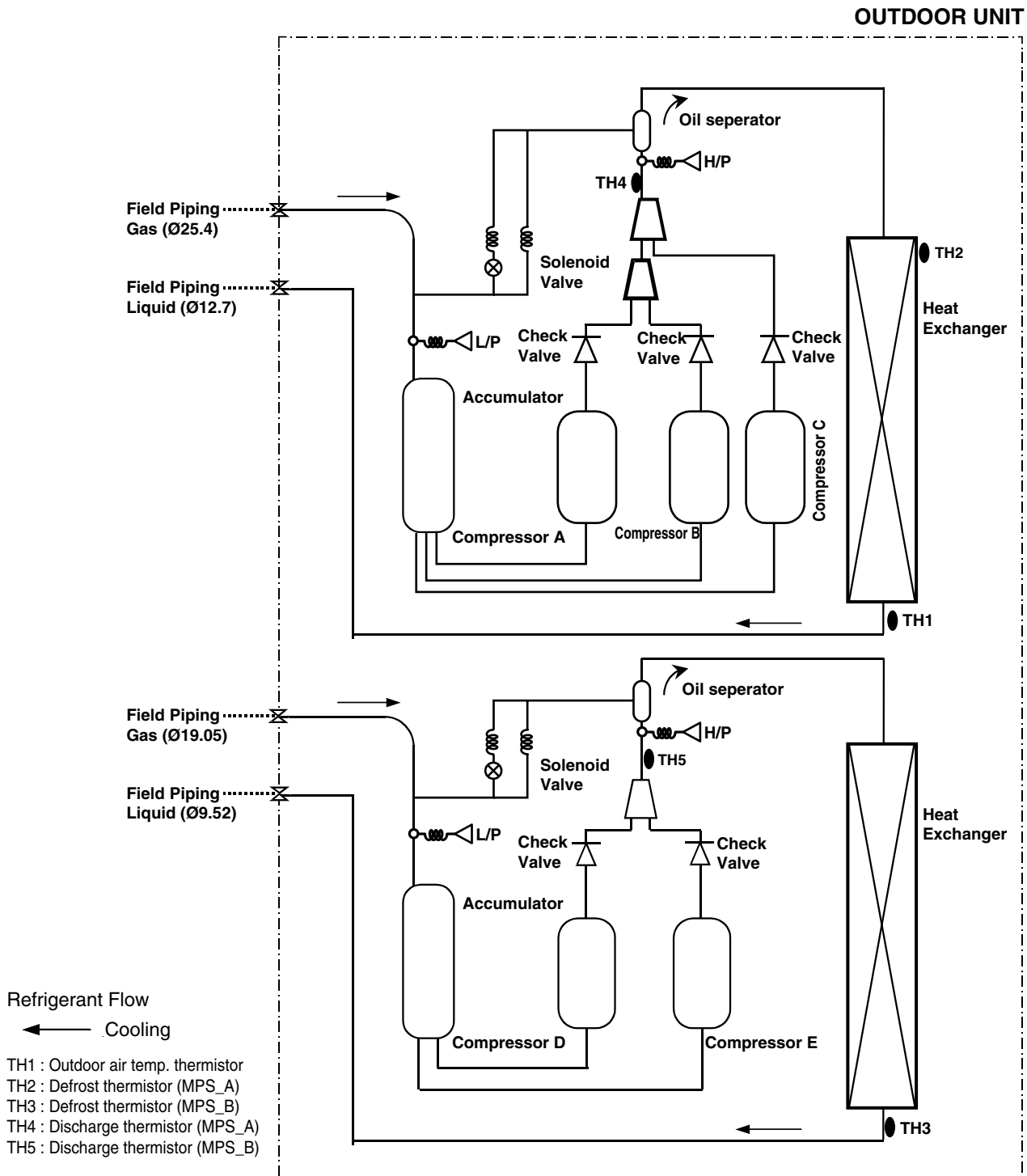

| LOC. | Description | PCB Connector |
|------|------------------------------|---------------|
| TH1 | Outdoor air temp. thermistor | CN_TH1 |
| TH2 | Defrost thermistor (MPS_A) | |
| TH3 | Defrost thermistor (MPS_B) | CN_TH2 |
| TH4 | Discharge thermistor (MPS_A) | |
| TH5 | Discharge thermistor (MPS_B) | CN_TH3 |

4. Wiring Diagrams

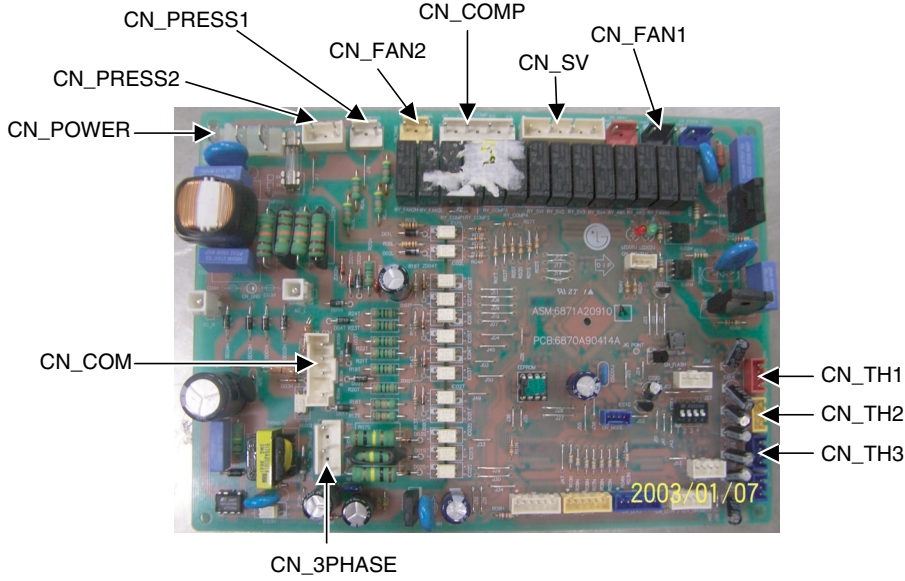
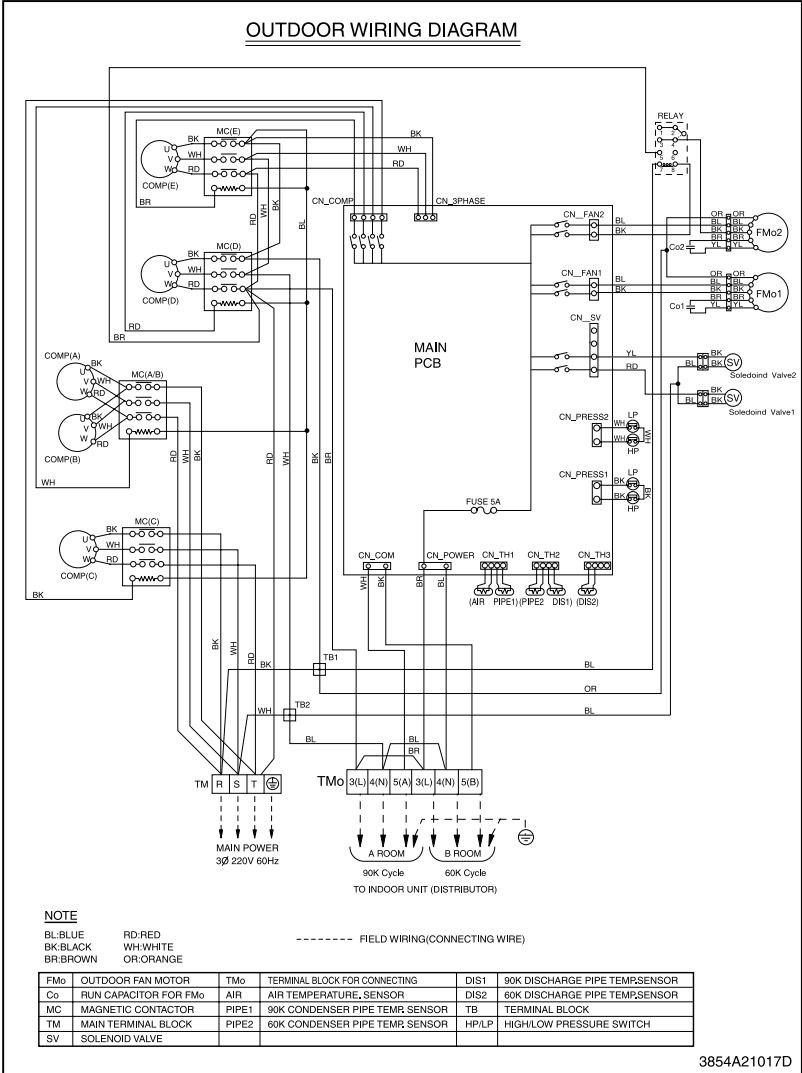

5. Exploded View

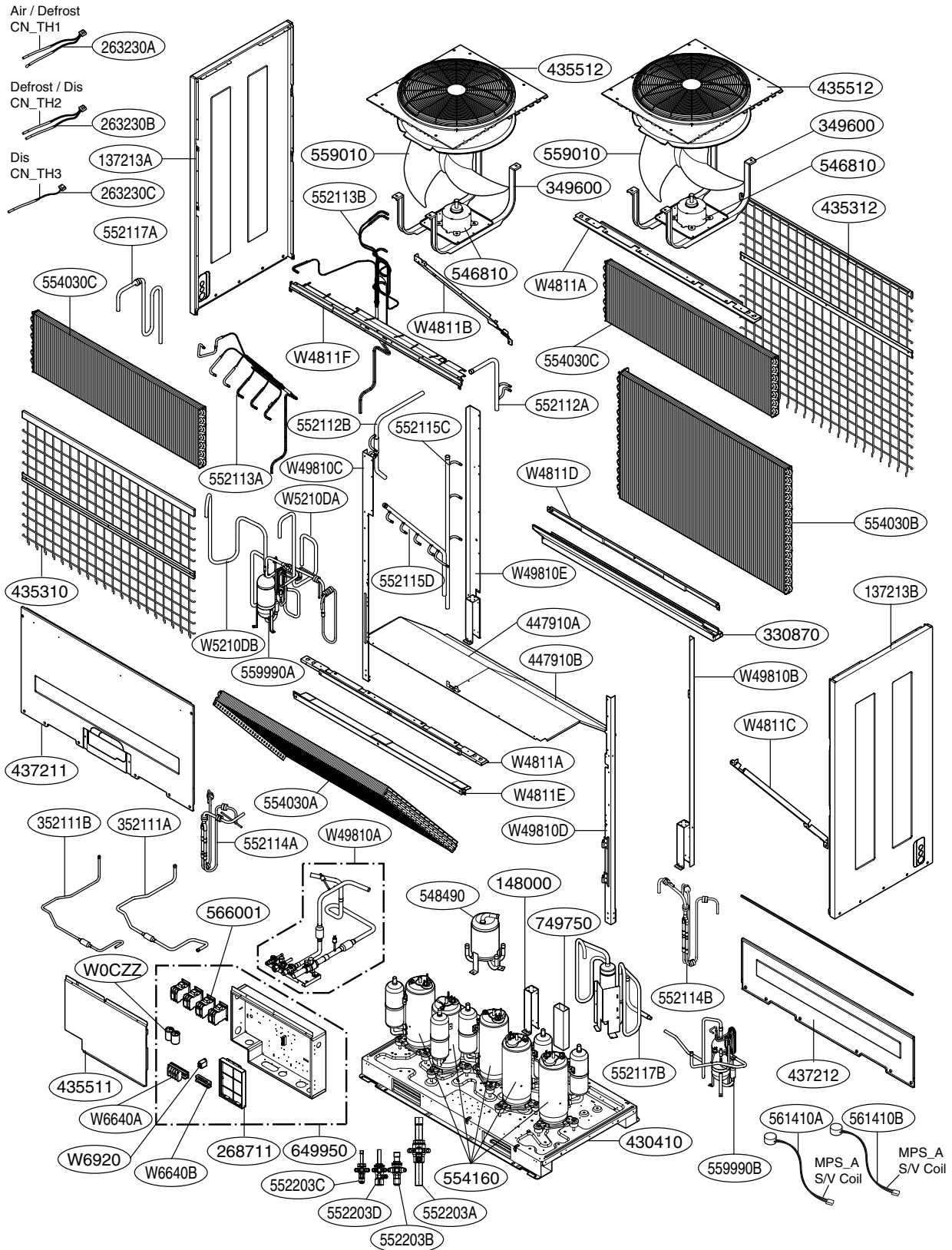

Note) * Please ensure GCSC since the replacement parts may be changed depending upon the buyer's request. Please check the correct parts in View RPL(Replacement Part List) on GCSC. (GCSC Website <http://biz.Lgservice.com>.)



P/NO : MFL39632202

September, 2009