



Service Manual

Dishwasher ADP 941 WH

Model Version		Page
	ADP 941 WH 8542 941 15010	
	Technical data	2 - 4
	Spare part list	5 - 6
	Exploded view	7 - 8
	Circuit diagram	9
	Program diagram	10
	Text/Legend	11 - 19
	Family	A4

Technical data**Dimension**

Height	85,0	cm
Width	59,5	cm
Depth	60,0	cm
Weight	56,7	kg

Decor plate

Thicknes max.	4	mm
Width	584	mm
Height	595	mm
Weight max.	1,8	kg

Specification (normal program)

Capacity	12	standard setting pl.
Water consumption	22	l
Energy consumption	1,5	kWh
Program time	~ 82	min
Noise level	52	db (A)
Detergent consumption	25	ml
Salt consumption by 21° dh	<20	g
Hot water connect. up to	60	°C

Alarms

Refill rinse aid
Refill salt

Program information

Start indicator
Net indicator

Volume (normal program)

Water	Volume	Level
Regeneration	0,3 l	15 mm
Back rinse 3x	1,0 l	68 mm
Prewash	5,0 l	125 mm
Main wash	6,0 l	129 mm
Intermediate rinse 1	5,0 l	125 mm
Clear rinse	5,0 l	125 mm
Safety / overflow	8,5 l	141 mm

Measuring the level

Remove the coarse sieve, put in a measuring meter into the sump, measure the hight of the water level.

Detergent max.

Pre-wash	10	cm ³
Main-wash	45	cm ³
Rinse aid	125	cm ³
6 Dosage steps	1 - 6	cm ³

Water softener

Saltcontainer	2	kg
Resin container	900	cm ³
Regeneration dosage	300	cm ³

Water pressure

Inlet pressure	0,3-10	bar
Spray pump pressure	0,4	bar

Rotations

Spray pump motor	2800	RPM
Drain pump motor	2800	RPM
Spray arm lower	~ 30	RPM
Spray arm upper	~ 35	RPM
Ceiling rotor	~ 60	RPM

Flow rates / Inlet volume

Flow meter (at 0,3 bar = quantity 1,1 l/min)	208	Imp/l
Spray pump	~ 70	l/min
Drain pump	16	l/min
Pump height max.	1,3	m
Inlet valve	4,5	l/min
Valve for sieve	8	l/min
Spray arm lower	33	l/min
Sprayarm upper	30	l/min
Ceiling rotor	8	l/min

Water distribution

Fine sieve	100	%
Self cleaning micro filter	~ 32	%

Electrical data**Base data**

Voltage	230	V
Frequency	50	Hz
Total power	~ 3	kW
Fuse	13	A

Technical data

Motor

Spray pump motor

Voltage	220/230	V
Power consumption	~190	W
HI	69	Ω
HA	36,2	Ω
Capacitor	4	μ F

Drain pump motor

Voltage	220/240	V
Resistance	146	Ω

Heating

1 Element system

Voltage	240	V
Power consumption	2800	W
Resistance	9,3 - 10	Ω
Heating speed	~ 2,5	$^{\circ}$ C/min
Temperature on surface	~ 115	$^{\circ}$ C
Double safety thermostat self reset	85	$^{\circ}$ C

Potentiometer

Position 0	2,0	k Ω
Position 1	4,3	k Ω
Position 2	9,0	k Ω
Position 3	13,3	k Ω
Position 4	17,5	k Ω
Position 5	22,2	k Ω
Position 6	24,2	k Ω

Water valves

Single valve at inlet hose

Voltage	220/240	V
Frequency	50/60	Hz
Resistance	3,67	k Ω

Regenerating valve

Voltage	220/240	V
Frequency	50/60	Hz
Resistance	3,13	k Ω

Valve for sieve

Voltage	220/240	V
Frequency	50/60	Hz
Resistance	3,83	k Ω

Coil of dispenser

Voltage	220/240	V
Frequency	50/60	Hz
Resistance	1,43	k Ω

Relay

Heating relay

Voltage	220/240	V
Frequency	50/60	Hz
Resistance	5,5	k Ω

Reedcontact

flow meter
salt control
rinse aid control

NTC

15 $^{\circ}$ C	75 k Ω
20 $^{\circ}$ C	62 k Ω
30 $^{\circ}$ C	43 k Ω
40 $^{\circ}$ C	28 k Ω
50 $^{\circ}$ C	19 k Ω
60 $^{\circ}$ C	13 k Ω
70 $^{\circ}$ C	9 k Ω
80 $^{\circ}$ C	6 k Ω
85 $^{\circ}$ C	5 k Ω

Technical data

Regeneration

Volume	300	cm ³
Position 0 after wash cycles water hardness	-- 0-5 0-0,9 0-9	°dh mmol/l °Fh
Position 1 after wash cycles water hardness	6-8 6-10 1-1,8 10-18	°dh mmol/l °Fh
Position 2 after wash cycles water hardness	5-6 11-15 1,9-2,7 19-27	°dh mmol/l °Fh
Position 3 after wash cycles water hardness	4 16-21 2,8-3,7 28.37	°dh mmol/l °Fh
Position 4 after wash cycles water hardness	3 22-28 3,8-5,0 38-50	°dh mmol/l °Fh
Position 5 after wash cycles water hardness	2 29-35 5,1-6,3 51-63	°dh mmol/l °Fh
Position 6 after wash cycles water hardness	1 36-60 6,4-10,7 64-107	°dh mmol/l °Fh
Salt consumption for regeneration	77	g
Number of cycles with 2 kg salt	26	

Spare part list

Model ADP 941 WH
Service No. 854294115010
Version 854294115010

Pos. No.	12NC Code	Description
003 0	4812 440 18947	Traverse
004 0	4812 440 18952	Drip tray assy
004 1	4812 401 18402	Holder
011 0	4812 505 18357	Foot
022 0	4812 440 18951	Side panel left
022 1	4812 440 18949	Side panel right
022 2	4812 440 18953	Spacer
024 0	4812 440 18948	Panel, rear
030 0	4812 310 18303	Table top WH
034 0	4812 404 78237	Spacer
034 1	4812 404 78236	Fastener
040 1	4812 417 18774	Hinge left
040 2	4812 417 18773	Hinge right
040 3	4812 417 18784	Protection f.door (set)
044 0	4812 492 38354	Spring f.door
044 1	4812 492 38356	Spring f.cap
047 0	4812 404 48591	Brake f.door
047 1	4812 401 18397	Band,brake
047 2	4812 404 68023	Hook
047 3	4812 500 28001	Bolt
053 0	4812 440 88098	Plinth
061 0	4812 466 88455	Counter weight
103 0	4812 440 18978	Door outer
120 0	4812 440 18961	Door,inner
120 1	4812 440 18955	Batten
130 0	4812 417 58361	Tilt lock
131 0	4812 401 18403	Hook lock
191 0	4812 466 68494	Gasket door
192 0	4812 466 68467	Gasket, door lower
200 0	4812 418 18175	Container
241 0	4812 458 18276	Basket upper straight
241 1	4812 458 18284	Holder cups right
241 3	4812 528 88068	Wheel,basket upper (set)
241 8	4812 466 68482	Spacer cap set
242 0	4812 458 18274	Basket lower cpl.
242 1	4812 528 88069	Wheel,basket lower
242 2	4812 458 18262	Plate,support f.basket lower
242 3	4812 458 18275	Plate,support f.basket lower
243 0	4812 458 18272	Basket cutlery
243 3	4812 458 18289	Basket cutlery cpl.
261 0	4819 462 38271	Rail telescope, inner
261 1	4819 404 48819	Cap rail
261 2	4812 462 78995	Cap rail ahead
263 0	4819 520 18013	Ball cage cpl.
263 1	4812 520 48001	Ball Niro 8 D
265 0	4812 404 48599	Basket adjustm. cpl.
265 2	4812 404 48589	Grip basket adjustment
301 0	4812 453 79538	Control panel WH
303 1	4812 417 58364	Child-prooflock cpl. WH
305 0	4812 440 18964	Batten WH

Pos. No.	12NC Code	Description
322 0	4812 453 79552	Insert panel WH
331 0	4812 413 58864	Knob program cpl. WH
332 0	4812 410 28528	Push button cap WH
350 0	4812 276 58037	Display board (DB)
351 1	4812 381 28021	Guide,light
400 0	4812 259 28654	Motor with spray pump cpl.
405 0	4812 360 18358	Spray pump
405 1	4819 515 28158	Gasket
420 0	4812 121 18132	Capacitor
430 0	4812 360 18357	Pump,draining
430 1	4812 466 68506	Ring,sealing
450 0	4812 259 28655	Heating element
480 0	4812 321 28364	Cable harness set
490 0	4812 321 18019	Cable,mains 5,0m
490 0	4812 321 18026	Cable,mains 3m
490 0	4812 321 18028	Cable,mains 1,6m
521 0	4812 214 78138	Control board (CB)
531 0	4812 273 18051	Switch waterhardness
531 1	4812 273 18052	Wheel,fingertip
571 0	4812 281 28365	Valve inlet
571 2	4812 281 28362	Sieve valve
575 0	4812 281 28361	Regen.valve
581 0	4812 349 28003	Counter water
583 0	4812 271 28355	Switch diaphragm
612 0	4812 280 58018	Relay heating
616 0	4812 281 18047	Contact,reed salt
616 1	4812 271 58161	Contact,reed rinsing agent
620 0	4812 218 38012	User board (UB)
623 0	4812 271 38356	Microswitch
633 0	4812 271 38355	Microswitch
680 0	4812 418 68133	Combidosage
680 1	4812 466 68495	Gasket
680 2	4812 281 68004	Coil cpl.
681 1	4812 466 68497	Gasket
681 2	4812 440 18975	Flap
682 0	4812 466 68496	Gasket
691 0	4812 282 68012	Feeler NTC
701 0	4819 530 28283	Hose, inlet 2m
701 1	4812 310 18302	Yoke
701 2	4822 480 50159	Sieve inlet
710 0	4812 418 68128	Monoblock
710 2	4819 310 38536	Nut threaded ring set
710 3	4819 466 69562	Gasket set
714 0	4812 462 78993	Threaded cap
714 2	4812 440 18963	Cabinet non-return flap
716 0	4812 418 68141	Reg.dosage
716 1	4812 466 68475	Gasket
716 2	4812 462 78994	Cover
721 0	4812 360 68043	Hub lower cpl.
721 1	4812 360 68047	Arm,spray lower cpl.

Spare part list

Pos. No.	12NC Code	Description
721 2	4812 466 68491	Gasket 25x2,3B
721 3	4812 466 68489	Gasket 76x2,5
721 4	4812 418 18176	Cabinet
722 0	4812 360 68044	Arm,spray upper
722 2	4812 360 68048	Hub upper straight cpl.
723 0	4812 360 68049	Arm,spray
723 1	4812 466 68483	Gasket
723 2	4812 404 48597	Clip,fix sparayarm
723 3	4812 505 18362	Connect,gaspipe
726 0	4812 530 28786	Tube
726 1	4812 530 28787	Tube
726 2	4812 505 18358	Nut
726 3	4812 466 68512	Gasket
726 4	4812 462 79633	Centering
743 0	4812 511 48171	Capacitor
743 1	4812 530 28102	Hose inlet
743 3	4812 505 18364	Nut
743 4	4812 530 28807	Hose 9x1,5x270+10
743 7	4812 466 68514	Gasket
751 0	4812 418 18169	Water collector
751 1	4812 418 18171	Water guide
751 2	4812 440 18954	Fastener frame
755 0	4812 530 28785	Bend
755 2	4812 530 48136	Tray,leak left
755 3	4812 530 48137	Tray,leak right
756 0	4812 360 58099	Floater
761 0	4812 480 58061	Sieve fine
761 1	4812 480 58072	Sieve insert
762 0	4812 480 58065	Microfilter
763 0	4812 480 58057	Sieve coarse
781 0	4812 530 28737	Hose,draining
781 1	4819 530 28286	Sleeve hose
781 2	4819 492 68405	Clip f.non-return valve
781 3	4812 281 28364	Flap non-return
783 0	4812 530 28792	Hose 11,5x3x200

Pos. No.	12NC Code	Description
783 4	4812 530 28793	Hose 10x3x230
783 5	4812 530 28797	Distributor
783 6	4812 530 28796	Hose 10x3x180+10
791 0	4812 532 68063	Gasket
791 2	4812 530 58093	Gasket
791 3	4812 466 68502	Gasket
791 4	4812 466 68503	Gasket
791 5	4812 466 68504	Gasket
791 6	4812 466 68505	Gasket
794 1	4819 530 58032	Gasket 20x2,5
901 0	4812 401 18191	Strap 017,8
901 1	4812 401 18396	Strap
901 2	4812 401 18401	Strap 32-50
901 3	4812 401 18404	Strap 019,8-708 Z
901 5	4812 401 18406	Strap 028,6-708 Z
901 6	4812 401 18408	Strap 038,1-708 Z
902 0	4812 401 18195	Clip
904 2	4812 462 79635	Cover WH 3,5x5
904 3	4812 462 79636	Cover WH 3,5x4
910 0	4812 502 18362	Screw 4x35-TORX
910 1	4812 502 18019	Screw
910 2	4812 502 18363	Screw 4,0x12-H
910 3	4812 502 18364	Screw 5x20-TORX
910 4	4812 502 18365	Screw 3,5x5,5-TORX
910 5	4812 502 18367	Screw 3,5x8-TORX T15
910 6	4812 502 18369	Screw A2F M4x6
910 7	4812 502 38132	Screw DIN 965
964 0	4812 466 68468	Gasket housing ri/le
964 1	4812 466 68469	Gasket housing upper
993 0	4819 530 28279	Bow
993 5	4822 532 80216	Funnel salt

Exploded view

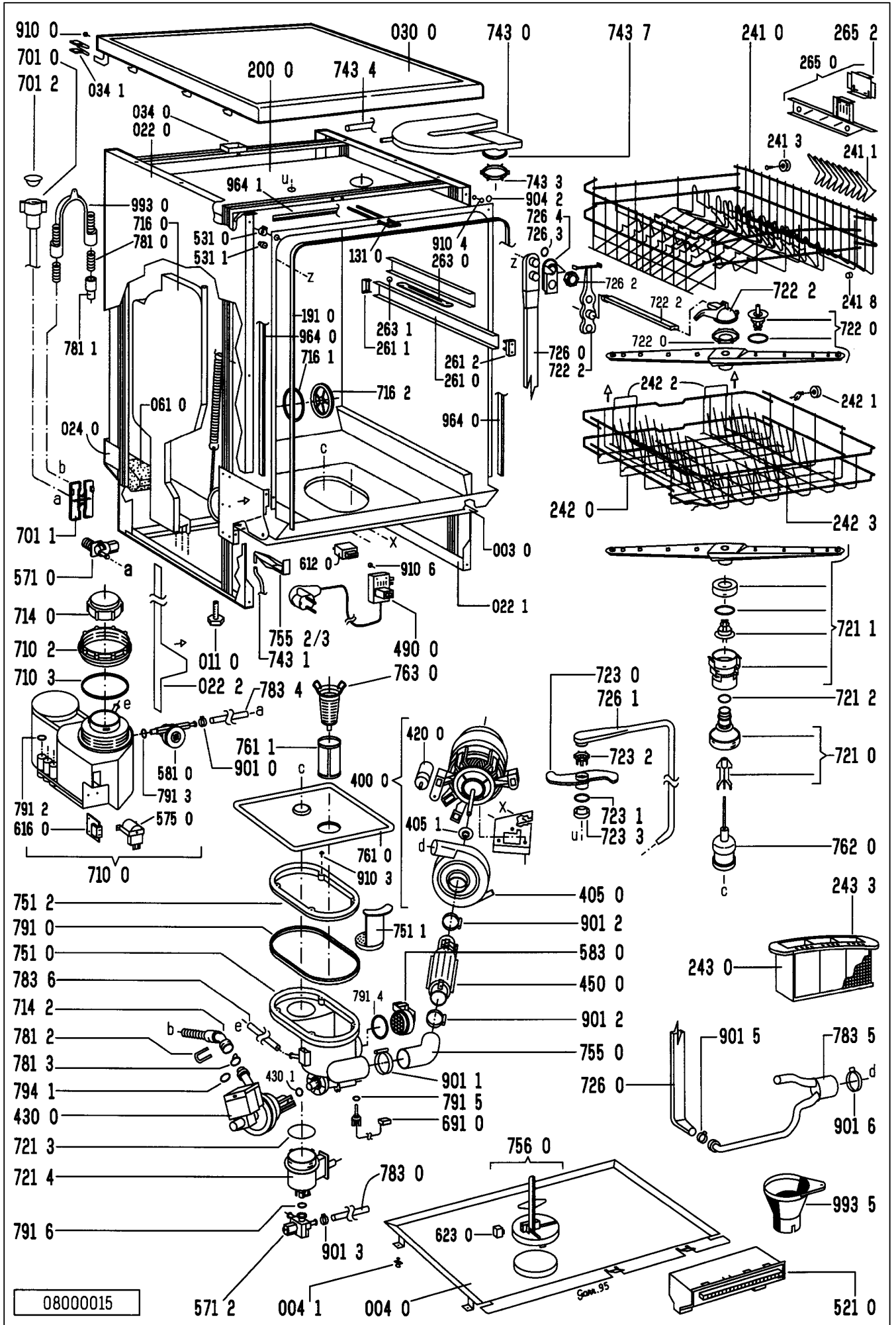

Exploded view

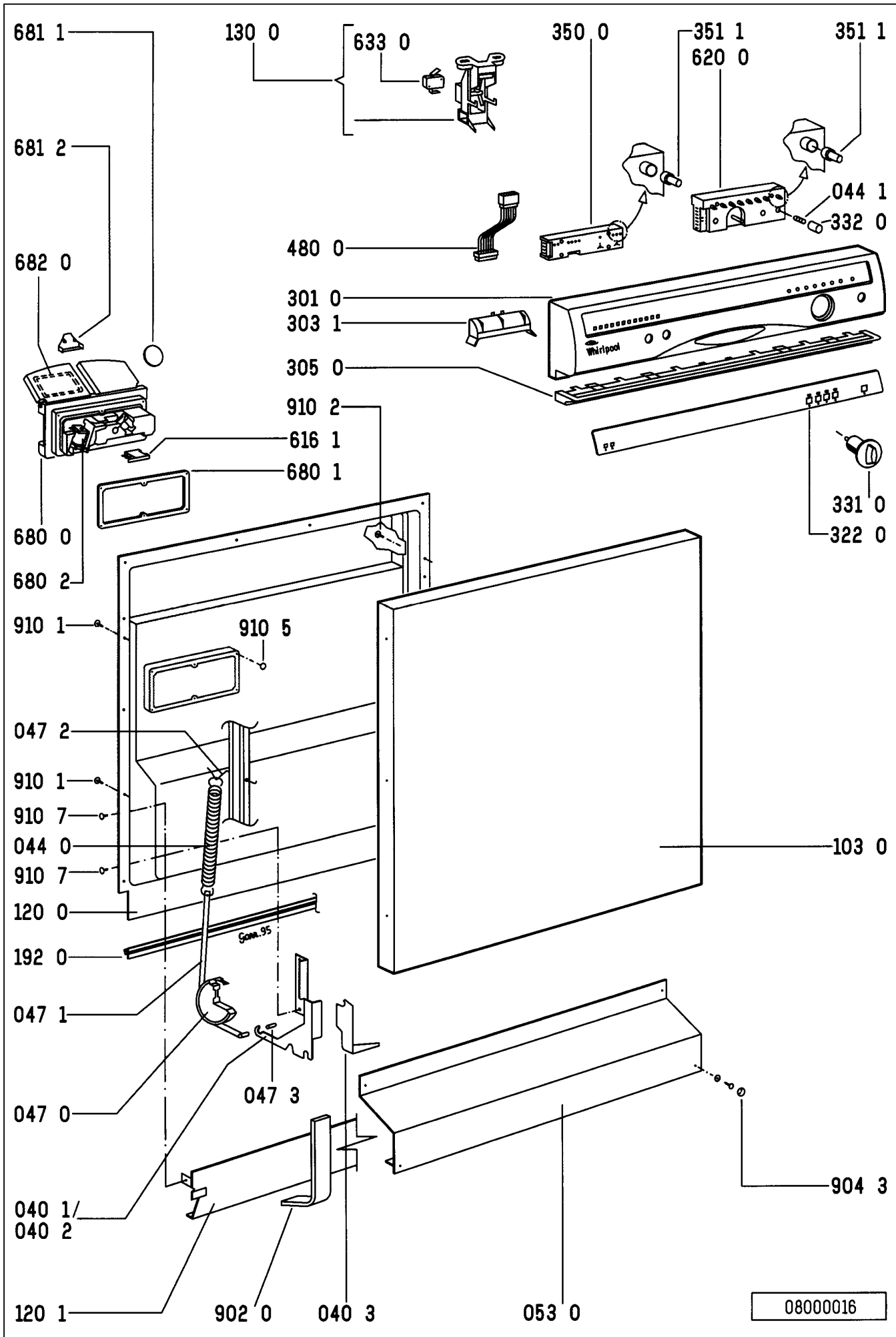

Circuit diagram

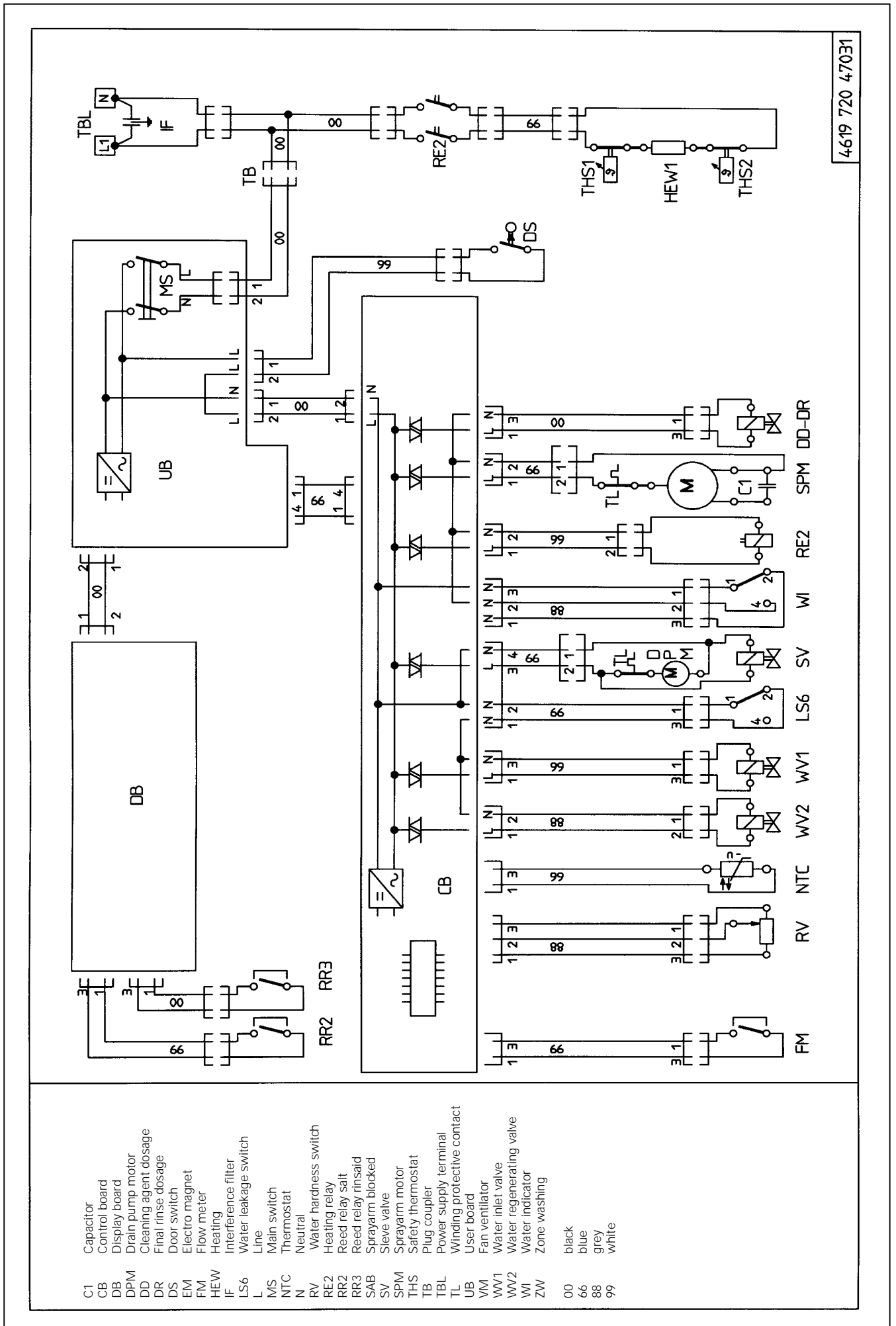

- C1 Capacitor
- CB Control board
- DB Display board
- DPM Drain pump motor
- DD Cleaning agent dosage
- DR Final rinse dosage
- DS Door switch
- EM Electro magnet
- FM Flow meter
- HEW Heating
- IF Interference filter
- LS6 Water leakage switch
- L Line
- MS Main switch
- NTC Thermostat
- N Neutral
- RV Water hardness switch
- RE2 Heating relay
- RE3 Reed relay salt
- RR2 Reed relay rinsaid
- RR3 Reed relay blocked
- SAB Sprayarm blocked
- SV Sleeve valve
- SPM Sprayarm motor
- THS Safety thermostat
- TB Plug coupler
- TBL Power supply terminal
- TL Winding protective contact
- UB User board
- VM Fan ventilator
- WI Water inlet valve
- WR Water regenerating valve
- ZW Water indicator
- ZS Zone washing

- 00 black
- 66 blue
- 88 grey
- 99 white

Program diagram

- no program function
 - contact or triac closed
- FM... amount of water
t2 heating time up to temp.
t3 draining time up to the water indicator is low

function of the machine

Start position for all Progr.

Start position for all Progr.	1	contacts										program table											
		VM	ZW	DD-DR	SPM	RE2	WI	SV	DPM	WV2	WV1	WV1	WV2	DPM	SV	WI	RE2	SPM	DD-DR	ZW	VM	Program Sequence LEDs	
draining	1																						PS1
filling	2																						
draining	3																						
filling	4																						
draining	5																						
filling	6																						
draining	7																						
filling - rinsing	8																						
rinsing - heating	9																						
rinsing	10																						
rinsing - draining	11																						
filling - rinsing	12																						
rinsing - dos. detergent	13																						
rinsing - heating	14																						
rinsing	15																						
rinsing - heating	16																						
rinsing	17																						
rinsing - draining	18																						
filling - rinsing	19																						
rinsing	20																						
rinsing - draining	21																						
filling - rinsing	22																						
rinsing	23																						
rinsing - draining	24																						
filling - rinsing	25																						
rinsing - heating	26																						
rinsing - dos. rinse aid	27																						
rinsing	28																						
rinsing - dos. rinse aid	29																						
rinsing - heating	30																						
rinsing	31																						
draining	32																						
drying - without Fan	33																						
drying - regenerating	34																						
drying - regenerating - draining	35																						
drying - regenerating	36																						
drying - regenerating - filling	37																						
drying - regenerating	38																						
drying - regenerating - filling	39																						
drying - draining	40																						
drying	41																						
drying - draining	42																						
End	43																						PS4

	1	contacts										LEDs											
		VM	ZW	DD-DR	SPM	RE2	WI	SV	DPM	WV2	WV1	PS1	PS2	PS3	PS4	ZW							
draining	1																						
filling	2																						
draining	3																						
filling	4																						
draining	5																						
filling	6																						
draining	7																						
filling - rinsing	8																						
pause - dos. detergent	9																						
rinsing - heating	10																						
regenerating	11																						
regenerating - draining	12																						
drying-regenerating-draining	13																						
End	14																						

Text/Legend

Test procedure for SERVICE-TEST-PROGRAM DOLPHIN dishwashers

1. Start the test program.
If there is a defective component indicated, open the plinth and take out the control board.
2. Check the component.
Unplug the indicated component from the control board and check it by using an Ohm-measure equipment.
If the ohms are correct, check the cables to the component and check the component itself.
3. Check the control board.
4. Only if there is no reaction when pushing a push button or turning the rotary switch, then test with the test points.
5. At the end of the repair start the test program again to see that the failure is solved.

More details: s. chapter test program for service.

Attention:

First unplug the appliance, then set the connection clamps of the volt measurement on the test points.

Danger for short circuit.

More details see chapter test point.

Short circuits on components can damage the control board.

If electronic boards are wet, do not switch the appliance on.

The failures F1 NTC break

F2 water leakage

F9 continuous water inlet

are checked and indicated immediately after start of the program.

Therefore these failures have to be solved before starting the test program.

When these failures are not solved, the test program does not run.

The electrical components get their voltage via triac from the control board. For testing the volume of voltage the volt meter must be parallel to the component (the component must be plugged on). If the component is plugged off, then on the plug the measured voltage is reduced.

Indication of failure and alarms

Whirlpool and Ignis appliances

failure	failure no.	indication	indication within test program
NTC - break	F1	start LED flashes	PS1 flashes
water leakage failure	F2	start LED flashes	PS2 flashes
heating system failure	F3	start LED flashes	PS3 flashes
draining failure	F4	start LED flashes	PS4 flashes
spray arm blocked	F5	PS1 flashes	PS1 + PS4 flash
water tap closed	F6	start LED flashes	PS2 + PS4 flash
flow meter failure	F7	start LED flashes	PS3 + PS4 flash
water level failure	F8	start LED flashes	PS2 + PS3 flash
water inlet continuously on	F9	start LED flashes	PS1 + PS3 flash
salt		alarm LED on	alarm LED on
rinse agent		alarm LED on	alarm LED on

Passive test program

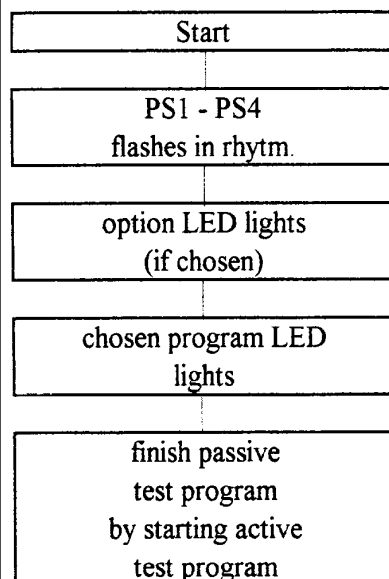

The passive test program shows the stored failure.

If there is no failure the passive test program runs normal.

Start procedure

1. Switch off the appliance
2. Push start button and hold it and select program BIO-ECO 50 °C (d)
3. Finish pushing the start button when the start LED flashes
4. Failure indication

Program sequence LED

PS1	1. LED	backrinsing prewash	
PS2	2. LED	mainwash intermediate rinse final rinse	
PS3	3. LED	drying	
PS4	4. LED end	goes off if any button is pushed	goes off after 30 min. progr. is finished

Indication of failure and alarms

Bauknecht appliances low and high version

failure	failure no.	indication without digits	indication with digits	indication within test program
NTC - break	F1	start LED flashes	F1 at digits	PS1 flashes F1 at digits
water leakage failure	F2	start LED flashes and alarm LED	alarm LED flashes	PS2 flashes F2 at digits
heating system failure	F3	start LED flashes	F3 at digits	PS3 flashes F3 at digits
draining failure	F4	start LED flashes	F4 at digits	PS4 flashes F4 at digits
spray arm blocked	F5	PS1 flashes	alarm LED flashes	PS1 + PS4 flash F5 at digits
water tap closed	F6	start LED flashes	alarm LED flashes	PS2 + PS4 flash F6 at digits
flow meter failure	F7	start LED flashes	F7 at digits	PS3 + PS4 flash F7 at digits
water level failure	F8	start LED flashes	F8 at digits	PS2 + PS3 flash F8 at digits
water inlet continuously on	F9	start LED flashes	alarm LED flashes (water leakage)	PS1 + PS3 flash F2 at digits
salt		alarm LED on	alarm LED on	alarm LED on
rinse agent		alarm LED on	alarm LED on	alarm LED on

With the passive test program all LEDs and buttons can be tested.

Passive test program

If there is no failure, the passive test program runs normal.

Start procedure

Start

ROTARY VERSION

PUSH BUTTON VERSION

PS1 - PS4
flashes in rhythm.

1. Switch off the appliance
2. Select program BIO/ECO (d)
3. Push start button and hold it and switch on the main switch
4. When start LED flashes, then release start button

1. Switch off the appliance
2. Push start button hold it and switch on the main switch
3. Release the start button when the start LED flashes
4. Select program BIO/ECO (d)

option LED lights
(if chosen)

chosen program LED
lights

Program sequence LED

finish passive
test program
by starting active
test program

PS1	1. LED	backrinsing prewash
PS2	2. LED	main wash intermediate rinse final rinse
PS3	3. LED	drying
PS4	4. LED end	goes off if any button is pushed
		goes off after 30 min. progr. is fin.

Active test program

All appliances Bauknecht, Whirlpool and Ignis

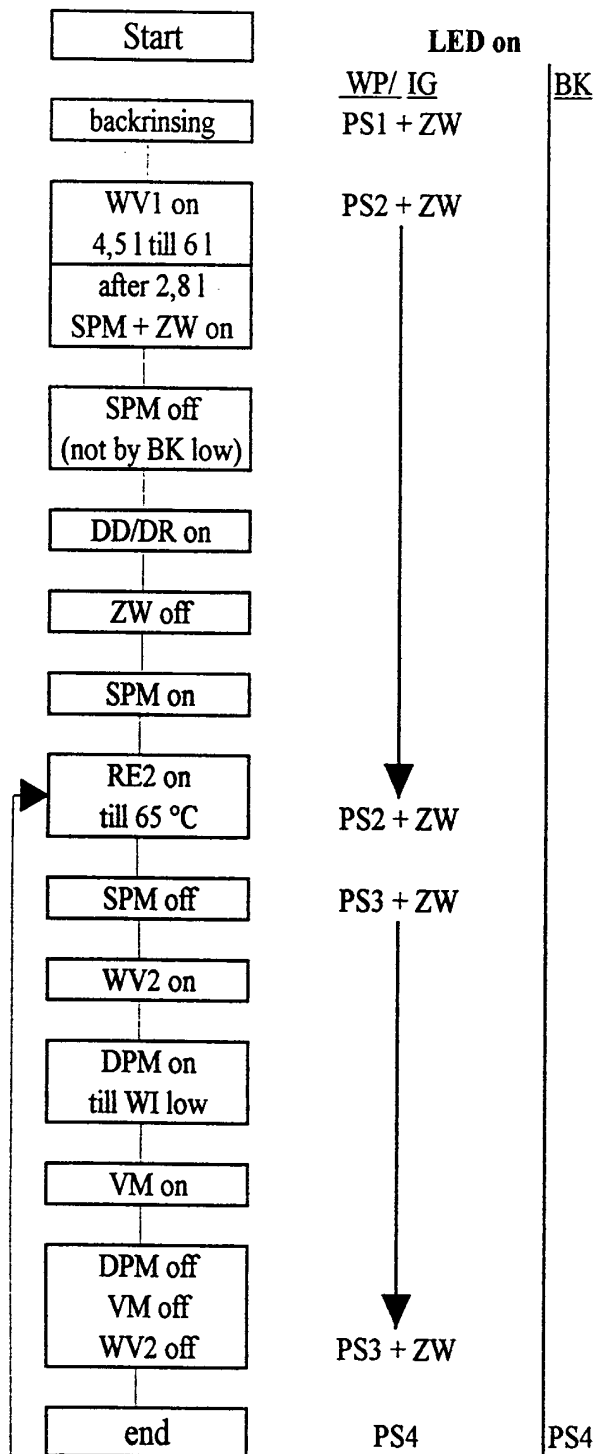

only on this step
can be jumped
to the next step
by short pushing
the start button
again

Test procedure

1. passive test program O. K.?
no: repair failure
yes: push start button shorter than 3 sec.
2. active test program starts

Remarks

The active test program runs to the failure position and stops or, if there is no failure, to the end.

The failure position is indicated:

On WP and IG appliances by switching off the flashing start LED.

On BK appliances the flashing start LED lights continuously.

To leave the test progr. push start button for longer than 3 sec.

Too less salt or too less rinse aid leads not to the stop of the appliance.

The function of the zone wash valve can only be checked optically.

A defect leads to an instable SPM pressure.

The function of the sieve valve can only be checked optically.

In case of defect the housing of the selfcleaning microfilter is not empty on the end of the program.

Appliances which have no program sequence LED/digits cannot show the failure.

On these appliances the failure can only be found by starting the test program and following this by using the program chart.

The steps of the test program are as normal.

Handling of failures**F1. NTC break**

- temperature out of the normal value (-10 degr. till +85 degr. C)

Possible failures

- heating higher than +85 degr. C
- NTC defective
- dishwasher is frozen, less than -10 degr. C

F2. water leakage

- water is in the drip tray
floater (LS6) switches off the WV1 and the electronic switches on the DPM till WI reports empty

F3. heating system defective

- too less heating speed (lower 1,5 degr. in 3 min.)
- heating (HEW) defective
- relais (RE2) defective

F4. draining failure

- drain pump starts and after 4 min. the WI detects not empty
- drain pump (DPM) defective
- syphon closed
- control board (CB) defective
- water indicator (WI) defective (is switched on)

F5. spray arm blocked (leads not to stop the appliance)

- SAB sensor sends less than 10 impulses/min.
- spray arm blocked or not fixed well
- selfcleaning microfilter blocked
- spray pump (SPM) does not work well
- SAB sensor defective

F6. water tap closed

water valve (WV1) is switched on but flow meter (FM) sends no impulses (less than 10 imp. in 10 sec.) and the water indicator (WI) is at low level

- water tap closed
- water inlet hose blocked
- water inlet valve (WV1) defective
- flow meter (FM) defective (leads to FM failure)

F7. flow meter failure

water inlet valve is switched on and the water indicator (WI) is switched on high level

- flow meter (FM) sends to less impulses (less than 10 imp. in 10 sec.)
- water tap closed
- water inlet hose blocked
- water inlet valve (WV1) defective
- flow meter (FM) defective
- water indicator (WI) is defective

F8. water level failure

failure monitored during spray pump is on and the water indicator switches back more than 10 times in 2 min.

- water indicator defective
- sieve blocked
- water strongly foams
- pot has turned off and is filled with spray water
- no stable spray pump (SPM) working

F9. continuous water inlet

water inlet valve (WV1) is switched off, water indicator (WI) on, flow meter (FM) sends impulses more than 10 imp. in 10 sec.

- water inlet valve (WV1) mechanically not closed
- triac (CB) for WV1 is closed

reaction: interval 30 sec. draining / 20 sec. tracing

For salt, rinse aid, zone wash valve, sieve valve failure see active test program.

			Programs												
BK	IG	WP	a	b	c	d B K	d W I	e B K	e W I	f	g	h	i	j	k
A3			X			X				X					
	A3	A3	X				X			X					
A4			X			X		X		X					
	A4	A4	X				X		X	X					
	A5	A5	X				X		X	X	X				
	A6	A6	X		X		X		X	X	X				
	A7		X	X	X		X		X	X	X				
B4			X			X		X		X					
B5			X			X		X		X	X				
		B5	X				X		X	X	X				
B6			X		X	X		X		X	X				
		B6	X		X		X		X	X	X				
		B7	X	X	X		X		X	X	X				
C5			X			X		X		X	X				
C6			X		X	X		X		X	X				
C7			X	X	X	X		X		X	X				
C11			X	X	X	X		X		X	X	X	X	X	X

- a prewash
- b glass 40 degr.
- c rapid 50 degr.
- d bio eco 50 degr.(BK without pre wash,WH IG with pre wash)
- e bio normal 50 degr.(BK with pre wash cold)
- e daily 65 degr.(only IG WH, without pre wash)
- f normal 65 degr.(with prewash cold)
- g intensive 70 degr.(with prewash 40 degr.)
- h -d- bio eco 50 degr.(BK without pre wash), + e-button
- i -e- bio normal 50 degr.(BK with pre wash cold) + e-button
- j -f- normal 65 degr.(with prewash cold) + e-button
- k -g- intensive 70 degr.(with prewash 40 degr.) + e-button

After starting a program this program is locked. That means neither by unplugging / switching of the appliance nor by setting an other program, the first setted program can be changed. Chancing of the program is only possible by pushing the start-button again for longer than 3 sec.

On appliances with seperate On-Off button the last used program is stored. That means if the customer wants to use the same program again he has only to press the on-button and the start-button.

Test points on the control board for Whirlpool and Ignis appliances

With these test points the function of the buttons and the rotary switch can be checked. The test points are in the service window on the control board.

For the test fine clamps, cables and volt meter with high input resistance are necessary.

Before setting the clamps on the test points, switch off the appliance.

Test points: T0 = common line T2 = analogue value
T1 = analogue value T3 = digital signal

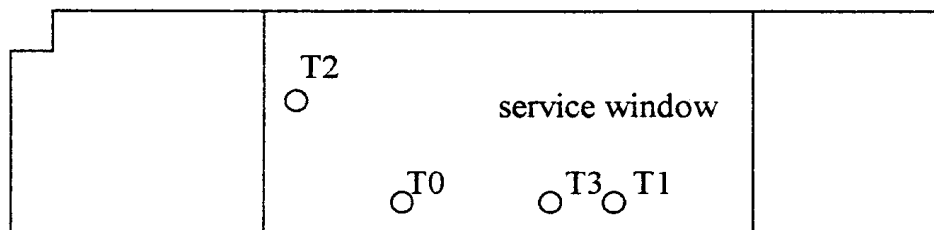

control board

Check: test point T0 to T1

Communication between Control board and Display board

pushed button	voltage	from	to
all off	appr. -6,19 V (DC)	control board	display board
ZW	appr. -3,69 V (DC)	display board	control board
delay start	appr. -2,33 V (DC)	display board	control board
ZW + delay start	appr. -1,85 V (DC)	display board	control board

Check: test point T0 to T2

Communication between Control board and User board

rotary switch	voltage	from	to
progr. a	appr. -1,54 V (DC)	user board	control board
progr. b	appr. -2,06 V (DC)	user board	control board
progr. c	appr. -2,57 V (DC)	user board	control board
progr. d	appr. -3,42 V (DC)	user board	control board
progr. e	appr. -3,96 V (DC)	user board	control board
progr. f	appr. -4,47 V (DC)	user board	control board
progr. g	appr. -5,00 V (DC)	user board	control board
start button	appr. 0,00 V (DC)	user board	control board

Check: test point T0 to T3

Communication between Control board and Display Board

multiplexing appr. -3,18 V (DC)

How exact the data are, depends on the measure equipment.

Test points on the control board for Bauknecht appliances

With these test points the function of the buttons and the rotary switch can be checked. The test points are in the service window on the control board.

For the test fine clamps, cables and volt meter with high input resistance are necessary.

Before setting the clamps on the test points, switch off the appliance.

Test points: T0 = common line T2 = analogue value T3 high = serial link
T3 low = digital signal

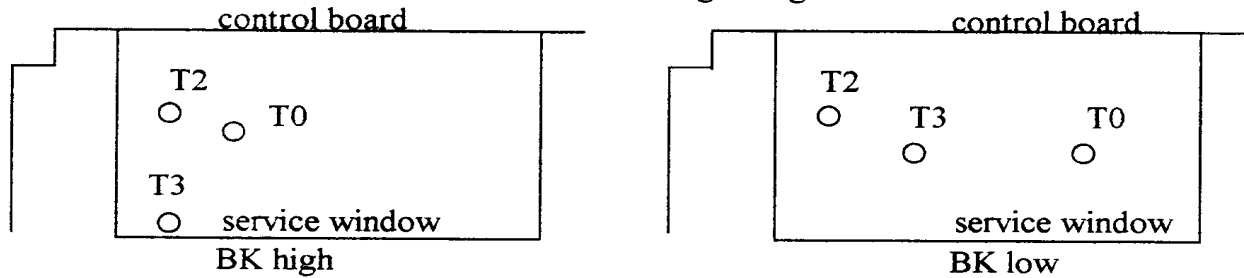

Check: test point T0 to T2 high range (see control board: BK-CB -H)

Communication between Control board and User board or Control- and Display board

pushed button or rotary switch	voltage	from	to
off	appr. -5,0 V (DC)	control board	user board
progr. a	appr. -1,0 V (DC)	user board	control board
progr. b	appr. -1,5 V (DC)	user board	control board
progr. c	appr. -2,0 V (DC)	user board	control board
progr. d (h)	appr. -2,5 V (DC)	user board	control board
progr. e (i)	appr. -3,0 V (DC)	user board	control board
progr. f (j)	appr. -3,5 V (DC)	user board	control board
progr. g (k)	appr. -4,0 V (DC)	user board	control board
start button	appr. -0,6 V (DC)	user board	control board
option- , gentle- or delay button	appr. -5,0 V (DC)	control board	display board

Check: test point T0 to T2 low range (see control board: BK-CB -L)

Communication between Control board and User board or Control- and Display board

pushed button or rotary switch	voltage	from	to
off	appr. -5,0 V (DC)	control board	user board
progr. a	appr. -1,0 V (DC)	user board	control board
progr. b	do not exist on low range		
progr. c	appr. -1,5 V (DC)	user board	control board
progr. d	appr. -2,0 V (DC)	user board	control board
progr. e	appr. -2,5 V (DC)	user board	control board
progr. f	appr. -3,0 V (DC)	user board	control board
progr. g	appr. -3,5 V (DC)	user board	control board
start button	appr. -0,6 V (DC)	user board	control board
eco-dry button	appr. -4,0 V (DC)	control board	display board
delay button	appr. -4,5 V (DC)	control board	display board

Check: test point T0 to T3 high range

no program running	-0,8/-1,0 V (DC)	control board	display board
program bio/eco running	-0,3/-0,8 V (DC)	control board	display board

Check: test point T0 to T3 low range

multiplex signal	-2,5 V (DC)	control board	display board
------------------	-------------	---------------	---------------

How exact the data are, depends on the measure equipment.