



---

# Service Manual

## Dishwasher

### ADP 952 WHM

---

<b>Model Version</b>		<b>Page</b>
	ADP 952 WHM	
	8542 952 61010	
	Technical data	2 - 4
	Spare part list	5 - 6
	Exploded view	7 - 8
	Circuit diagram	9
	Program diagram	10
	Text/Legend	11 - 19
	Family	B5

**Technical data**

**Dimension**

Height	82,0-87,0	cm
Width	59,5	cm
Depth	57,0	cm
Weight	~ 55,7	kg

**Decor plate**

Thicknes max.	4	mm
Width	584	mm
Height	595	mm
Weight max.	1,8	kg

**Specification (normal program)**

Capacity	12	standard setting pl.
Water consumption	19	l
Energy consumption	1,4	kWh
Program time	~ 78	min
Noise level	49	db (A)
Detergent consumption	25	ml
Salt consumption by 21° dh	<20	g
Hot water connect. up to	60	°C

**Alarms**

- Refill rinse aid
- Refill salt
- Sprayarm blocked

**Options**

- Delay timer
- Zone washing

**Program information**

- Start indicator
- Pre rinse/pre wash
- Main wash
- Drying
- End

**Volume (normal program)**

Water	Volume	Level
Regeneration	0,3 l	15 mm
Back rinse 3x	1,0 l	68 mm
Prewash	5,0 l	125 mm
Prewash/Zone washing	4,0 l	120 mm
Main wash	5,0 l	125 mm
Main wash/Zone washing	3,8 l	119 mm
Intermediate rinse 1	4,5 l	123 mm
Intermediate rinse 1/		
Zone washing	3,8 l	119 mm
Intermediate rinse 2	4,5 l	123 mm
Intermediate rinse 2/		
Zone washing	3,8 l	119 mm
Clear rinse	4,5 l	123 mm
Clear rinse/Zone washing	3,8 l	119 mm
Safety / overflow	8,5 l	141 mm

**Measuring the level**

Remove the coarse sieve, put in a measuring meter into the sump, measure the hight of the water level.

**Detergent max.**

Pre-wash	10	cm
Main-wash	45	cm
Rinse aid	125	cm
6 Dosage steps	1 - 6	cm

**Water softener**

Saltcontainer	2	kg
Resin container	900	cm
Regeneration dosage	300	cm

**Water pressure**

Inlet pressure	0,3-10	bar
Spray pump pressure	0,4	bar

**Rotations**

Spray pump motor	2800	RPM
Drain pump motor	2800	RPM
Spray arm lower	~ 30	RPM
Spray arm upper	~ 35	RPM
Ceiling rotor	~ 60	RPM

## Technical data

### Flow rates / Inlet volume

Flow meter (at 0,3 bar = quantity 1,1 l/min)	208	Imp/l
Spray pump	~ 70	l/min
Drain pump	16	l/min
Pump height max.	1,3	m
Inlet valve	4,5	l/min
Valve for Zone washing	30	l/min
Valve for sieve	8	l/min
Spray arm lower	33	l/min
Sprayarm upper	30	l/min
Ceiling rotor	8	l/min

### Water distribution

Fine sieve	100	%
Self cleaning micro filter	~ 32	%

### Electrical data

#### Base data

Voltage	220/230	V
Frequency	50	Hz
Total power	2,0-2,2	kW
Fuse	10	A

#### Motor

#### Spray pump motor

Voltage	220/230	V
Power consumption	~190	W
HI	69	$\Omega$
HA	36,2	$\Omega$
Capacitor	4	F

#### Drain pump motor

Voltage	220/240	V
Resistance	146	$\Omega$

### Heating

#### 1 Element system

Voltage	220/230	V
Power consumption	1,8/2,0	kW
Resistance	12,5-13,5	$\Omega$
Heating speed	~ 2,5	$^{\circ}\text{C}/\text{min}$
Temperature on surface	~ 115	$^{\circ}\text{C}$
Double safety thermostat self reset	85	$^{\circ}\text{C}$

### Potentiometer

Position 0	2,0	$\text{k}\Omega$
Position 1	4,3	$\text{k}\Omega$
Position 2	9,0	$\text{k}\Omega$
Position 3	13,3	$\text{k}\Omega$
Position 4	17,5	$\text{k}\Omega$
Position 5	22,2	$\text{k}\Omega$
Position 6	24,2	$\text{k}\Omega$

### Water valves

#### Single valve at inlet hose

Voltage	220/240	V
Frequency	50/60	Hz
Resistance	2,06	$\text{k}\Omega$

#### Regenerating valve

Voltage	220/240	V
Frequency	50/60	Hz
Resistance	3,13	$\text{k}\Omega$

#### Valve for zone washing

Voltage	220-240	V
Frequency	50/60	Hz
Resistance	3,71	$\text{k}\Omega$

#### Valve for sieve

Voltage	220/240	V
Frequency	50/60	Hz
Resistance	3,83	$\text{k}\Omega$

#### Coil of dispenser

Voltage	220/240	V
Frequency	50/60	Hz
Resistance	1,43	$\text{k}\Omega$

#### Relay

#### Heating relay

Voltage	220/240	V
Frequency	50/60	Hz
Resistance	5,5	$\text{k}\Omega$

**Technical data**

**Reedcontact**

flow meter  
 salt control  
 rinse aid control  
 Spray arm block

**NTC**

15 °C	75	kΩ
20 °C	62	kΩ
30 °C	43	kΩ
40 °C	28	kΩ
50 °C	19	kΩ
60 °C	13	kΩ
70 °C	9	kΩ
80 °C	6	kΩ
85 °C	5	kΩ

**Regeneration**

Volume	300	cm
Position 0 after wash cycles	--	
water hardness	0-5	°dh
	0-0,9	mmol/l
	0-9	°Fh
Position 1 after wash cycles	6-8	
water hardness	6-10	°dh
	1-1,8	mmol/l
	10-18	°Fh
Position 2 after wash cycles	5-6	
water hardness	11-15	°dh
	1,9-2,7	mmol/l
	19-27	°Fh
Position 3 after wash cycles	4	
water hardness	16-21	°dh
	2,8-3,7	mmol/l
	28.37	°Fh
Position 4 after wash cycles	3	
water hardness	22-28	°dh
	3,8-5,0	mmol/l
	38-50	°Fh
Position 5 after wash cycles	2	
water hardness	29-35	°dh
	5,1-6,3	mmol/l
	51-63	°Fh
Position 6 after wash cycles	1	
water hardness	36-60	°dh
	6,4-10,7	mmol/l
	64-107	°Fh
Salt consumption for regeneration	77	g
Number of cycles with 2 kg salt	26	

## Spare part list

Model **ADP 952 WHM**  
Service No. **854295261010**  
Version **854295261010**

Pos. No.	12NC Code	Description
004 0	<b>4812 440 18952</b>	Drip tray assy
004 1	<b>4812 401 18402</b>	Holder
011 0	<b>4812 505 18369</b>	Foot long
022 0	<b>4812 440 19362</b>	Side panel left
022 1	<b>4812 440 19361</b>	Side panel right
022 2	<b>4812 440 18953</b>	Spacer
024 0	<b>4812 440 18948</b>	Panel, rear
040 1	<b>4812 417 18774</b>	Hinge left
040 2	<b>4812 417 18773</b>	Hinge right
040 3	<b>4812 417 18784</b>	Protector f.door (set)
044 0	<b>4812 492 38354</b>	Spring f.door
044 1	<b>4812 492 38356</b>	Spring f.cap
047 0	<b>4812 404 48591</b>	Brake f.door
047 1	<b>4812 401 18397</b>	Band,brake
047 2	<b>4812 404 68023</b>	Hook
053 0	<b>4812 440 88106</b>	Plinth
053 1	<b>4812 440 19359</b>	Plinth
053 2	<b>4812 440 19363</b>	Angle iron
053 3	<b>4812 440 19358</b>	Plinth extension
061 0	<b>4812 466 88453</b>	Counter weight
065 0	<b>4812 466 48051</b>	Insulation
103 0	<b>4812 440 18956</b>	Door outer WH
120 0	<b>4812 440 18961</b>	Door,inner
120 1	<b>4812 440 18955</b>	Batten
130 0	<b>4812 417 58361</b>	Tilt lock
131 0	<b>4812 401 18403</b>	Hook lock
175 0	<b>4812 310 18295</b>	Trim,ornamental left WH
175 1	<b>4812 310 18294</b>	Trim,ornamental right WH
175 2	<b>4812 310 18296</b>	Trim,ornamental lower WH
191 0	<b>4812 466 68534</b>	Gasket door
192 0	<b>4812 466 68467</b>	Gasket, door lower
200 0	<b>4812 418 18183</b>	Container cpl.
241 0	<b>4812 458 18276</b>	Basket upper straight
241 1	<b>4812 458 18283</b>	Holder cups right WH to 96/09
241 1	<b>4812 458 18284</b>	Holder cups right GR from 96/09
241 2	<b>4812 535 78033</b>	Bearing cupholder
241 3	<b>4812 528 88068</b>	Wheel,basket upper (set)
241 4	<b>4812 458 18285</b>	Cutlerycomp. GR from 96/09
241 4	<b>4812 458 18288</b>	Cutlerycomp. WH to 96/09
241 5	<b>4812 458 18269</b>	Holder cutlery compartment
241 6	<b>4812 458 18286</b>	Holder cups left GR from 96/09
241 6	<b>4812 458 18287</b>	Holder cups left WH to 96/09
241 7	<b>4812 404 48605</b>	Hoop
241 8	<b>4812 466 68482</b>	Spacer cap set
242 0	<b>4812 458 18274</b>	Basket lower cpl.
242 1	<b>4812 528 88069</b>	Wheel,basket lower
242 2	<b>4812 458 18262</b>	Plate,support f.basket lower
242 3	<b>4812 458 18275</b>	Plate,support f.basket lower
243 0	<b>4812 458 18296</b>	Basket cutlery
243 3	<b>4812 458 18289</b>	Basket cutlery cpl.
243 4	<b>4812 458 18317</b>	Bracket
261 0	<b>4819 462 38271</b>	Rail telescope, inner
261 1	<b>4819 404 48819</b>	Cap rail
261 2	<b>4812 462 78995</b>	Cap rail ahead
263 0	<b>4819 520 18013</b>	Ball cage cpl.

Pos. No.	12NC Code	Description
263 1	<b>4812 520 48001</b>	Ball Niro 8 D
265 0	<b>4812 404 48599</b>	Basket adjustm. cpl.
265 2	<b>4812 404 48589</b>	Grip basket adjustment
301 0	<b>4812 453 79536</b>	Control panel WH
303 1	<b>4812 417 58364</b>	Child-prooflock cpl. WH
305 0	<b>4812 440 18964</b>	Batten WH
322 0	<b>4812 453 79562</b>	Insert panel WH
331 0	<b>4812 413 58865</b>	Knob program cpl. WH
332 0	<b>4812 410 28528</b>	Push button cap WH
350 0	<b>4812 276 58037</b>	Display board (DB)
351 1	<b>4812 381 28021</b>	Guide,light
400 0	<b>4812 259 28654</b>	Motor with spray pump cpl.
405 0	<b>4812 360 18358</b>	Spray pump
405 1	<b>4819 515 28158</b>	Gasket
420 0	<b>4812 121 18132</b>	Capacitor
430 0	<b>4812 360 18357</b>	Pump,draining
430 1	<b>4812 466 68506</b>	Ring,sealing
450 0	<b>4812 259 28657</b>	Heating element
480 0	<b>4812 321 28364</b>	Cable harness set
490 0	<b>4812 321 18019</b>	Cable,mains 5m (without plug)
490 0	<b>4812 321 18026</b>	Cable,mains 3m
490 0	<b>4812 401 18394</b>	Cable,mains 1,6m
521 0	<b>4812 214 78151</b>	Control board (CB) kit
531 0	<b>4812 273 18051</b>	Switch waterhardness
531 1	<b>4812 273 18052</b>	Wheel,fingertip
571 2	<b>4812 281 28362</b>	Sieve valve
571 3	<b>4812 281 28363</b>	Valve f.zone-washing
575 0	<b>4812 281 28361</b>	Regen.valve
581 0	<b>4812 349 28003</b>	Counter water
583 0	<b>4812 271 28355</b>	Switch diaphragm
612 0	<b>4812 280 58018</b>	Relay heating
616 0	<b>4812 281 18047</b>	Contact,reed salt
616 1	<b>4812 271 58161</b>	Contact,reed rinsing agent
616 2	<b>4812 271 58159</b>	Contact,reed
620 0	<b>4812 218 38005</b>	User board (UB)
623 0	<b>4812 271 38356</b>	Microswitch
633 0	<b>4812 271 38355</b>	Microswitch
680 0	<b>4812 418 68133</b>	Combidosage
680 1	<b>4812 466 68495</b>	Gasket
681 1	<b>4812 466 68497</b>	Gasket
681 2	<b>4812 440 18975</b>	Flap
682 0	<b>4812 466 68496</b>	Gasket
691 0	<b>4812 282 68012</b>	Feeler NTC
700 0	<b>4812 530 28788</b>	Hose, inlet aqua stop 2m
700 0	<b>4812 530 28804</b>	Hose, inlet aqua stop 4,2m
700 1	<b>4812 480 48019</b>	Sieve
700 2	<b>4812 520 58002</b>	Gasket set
700 3	<b>4812 462 78307</b>	Reductor
701 1	<b>4812 310 18153</b>	Yoke clamp set
701 2	<b>4819 401 18423</b>	Holder
710 0	<b>4812 418 68128</b>	Monoblock
710 2	<b>4819 310 38536</b>	Nut threaded ring set
710 3	<b>4819 466 69562</b>	Gasket set
714 0	<b>4812 462 78993</b>	Threaded cap
714 2	<b>4812 440 18963</b>	Cabinet non-return flap

## Spare part list

**Model** ADP 952 WHM  
**Service No.** 854295261010  
**Version** 854295261010

Pos. No.	12NC Code	Description
716 0	<b>4812 418 68141</b>	Reg.dosage
716 1	<b>4812 466 68475</b>	Gasket
716 2	<b>4812 462 78994</b>	Cover
721 0	<b>4812 360 68043</b>	Hub lower cpl.
721 1	<b>4812 360 68047</b>	Arm,spray lower cpl.
721 2	<b>4812 466 68491</b>	Gasket 25x2,3B
721 3	<b>4812 466 68489</b>	Gasket 76x2,5
721 4	<b>4812 418 18176</b>	Cabinet
722 0	<b>4812 360 68044</b>	Arm,spray upper
722 2	<b>4812 360 68048</b>	Hub upper straight cpl.
723 0	<b>4812 360 68049</b>	Arm,spray
723 1	<b>4812 466 68483</b>	Gasket
723 2	<b>4812 404 48597</b>	Clip,fix sprayarm
723 3	<b>4812 505 18362</b>	Connect,gaspipes
726 0	<b>4812 530 28786</b>	Tube
726 1	<b>4812 530 28787</b>	Tube
726 2	<b>4812 505 18358</b>	Nut
726 3	<b>4812 466 68512</b>	Gasket
726 4	<b>4812 462 79633</b>	Centering
743 0	<b>4812 511 48171</b>	Capacitor
743 1	<b>4812 530 28102</b>	Hose, inlet
743 3	<b>4812 505 18364</b>	Nut
743 4	<b>4812 530 28807</b>	Hose 9x1,5x270+10
743 7	<b>4812 466 68514</b>	Gasket
751 0	<b>4812 418 18169</b>	Water collector
751 1	<b>4812 418 18171</b>	Water guide
751 2	<b>4812 440 18954</b>	Fastener frame
755 0	<b>4812 530 28785</b>	Bend
755 2	<b>4812 530 48136</b>	Tray,leak left
755 3	<b>4812 530 48137</b>	Tray,leak right
756 0	<b>4812 360 58099</b>	Floater
761 0	<b>4812 480 58061</b>	Sieve fine
761 1	<b>4812 480 58072</b>	Sieve insert
762 0	<b>4812 480 58055</b>	Microfilter
763 0	<b>4812 480 58057</b>	Sieve coarse
781 0	<b>4812 530 28737</b>	Hose,draining
781 1	<b>4819 530 28286</b>	Sleeve hose
781 2	<b>4819 492 68405</b>	Clip f.non-return valve
781 3	<b>4812 281 28364</b>	Flap non-return
783 0	<b>4812 530 28792</b>	Hose 11,5x3x200
783 1	<b>4812 530 28806</b>	Hose connection
783 5	<b>4812 530 28789</b>	Distributor
783 6	<b>4812 530 28796</b>	Hose 10x3x180+10
791 0	<b>4812 532 68063</b>	Gasket
791 2	<b>4812 530 58093</b>	Gasket
791 3	<b>4812 466 68502</b>	Gasket 10x3,5
791 4	<b>4812 466 68503</b>	Gasket
791 5	<b>4812 466 68504</b>	Gasket
791 6	<b>4812 466 68505</b>	Gasket
794 1	<b>4819 530 58032</b>	Gasket 20x2,5
901 0	<b>4812 401 18191</b>	Strap 017,8
901 1	<b>4812 401 18396</b>	Strap
901 2	<b>4812 401 18401</b>	Strap
901 3	<b>4812 401 18404</b>	Strap 019,8-708Z
901 4	<b>4812 401 18405</b>	Strap 025,6-708Z

Pos. No.	12NC Code	Description
901 5	<b>4812 401 18406</b>	Strap 028,6-708Z
901 6	<b>4812 401 18408</b>	Strap 038,1-708Z
901 8	<b>4812 401 18393</b>	Strap 20-32/9
902 0	<b>4812 401 18195</b>	Clip
902 1	<b>4812 466 78361</b>	Fastener f.buildt-in models
902 2	<b>4812 404 78239</b>	Holder
904 2	<b>4812 462 79635</b>	Cover WH 3,5x5
904 3	<b>4812 462 79636</b>	Cover WH 3,5x4
910 1	<b>4812 502 18019</b>	Screw
910 2	<b>4812 502 18363</b>	Screw 4,0x12-H
910 3	<b>4812 502 18364</b>	Screw 5x20-TORX
910 4	<b>4812 502 18365</b>	Screw 3,5x5,5-TORX
910 5	<b>4812 502 18367</b>	Screw 3,5x8-TORX T15
910 6	<b>4812 502 18369</b>	Screw A2F M4x6
910 7	<b>4812 502 38132</b>	Screw DIN 965
911 0	<b>4812 502 38134</b>	Screw decor ST3,5x9,5-C-H
964 0	<b>4812 440 18947</b>	Traverse
964 0	<b>4812 466 68468</b>	Gasket housing ri/le
964 1	<b>4812 466 68511</b>	Gasket housing upper
993 1	<b>4812 466 78018</b>	Foil protection
993 2	<b>4812 404 48609</b>	Socket wrenc foot
993 5	<b>4822 532 80216</b>	Funnel salt

## Exploded view

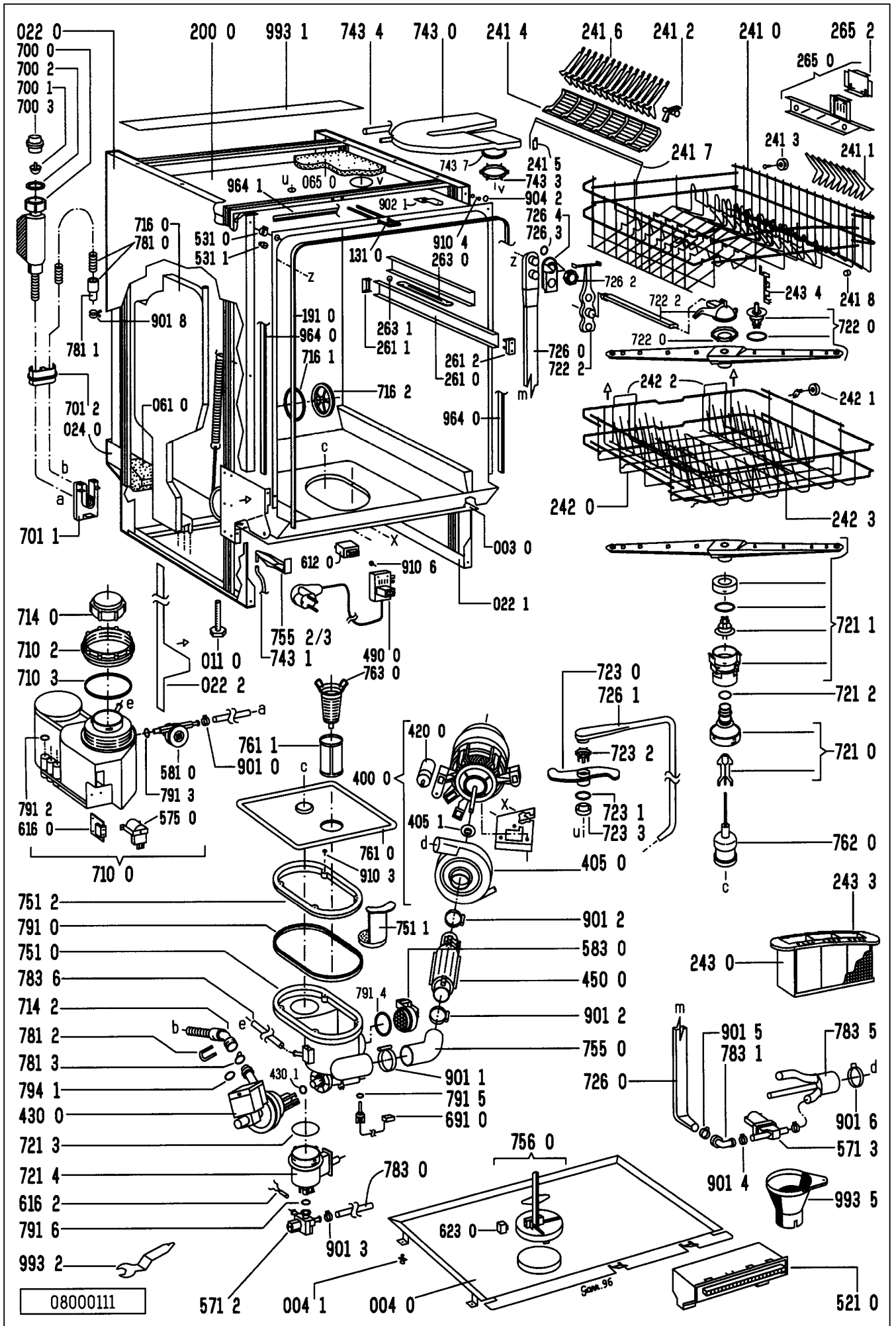

**Exploded view**

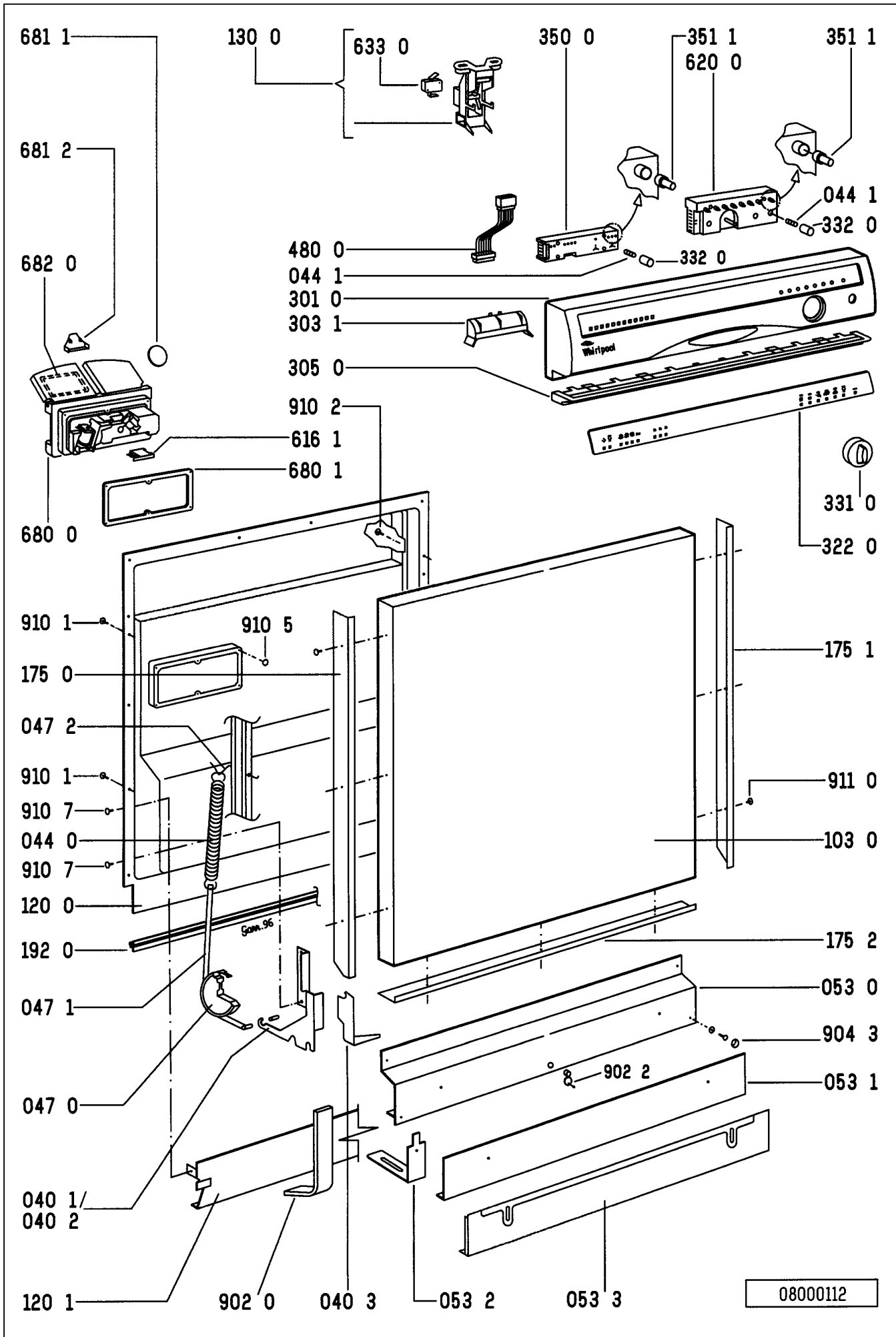



## Circuit diagram

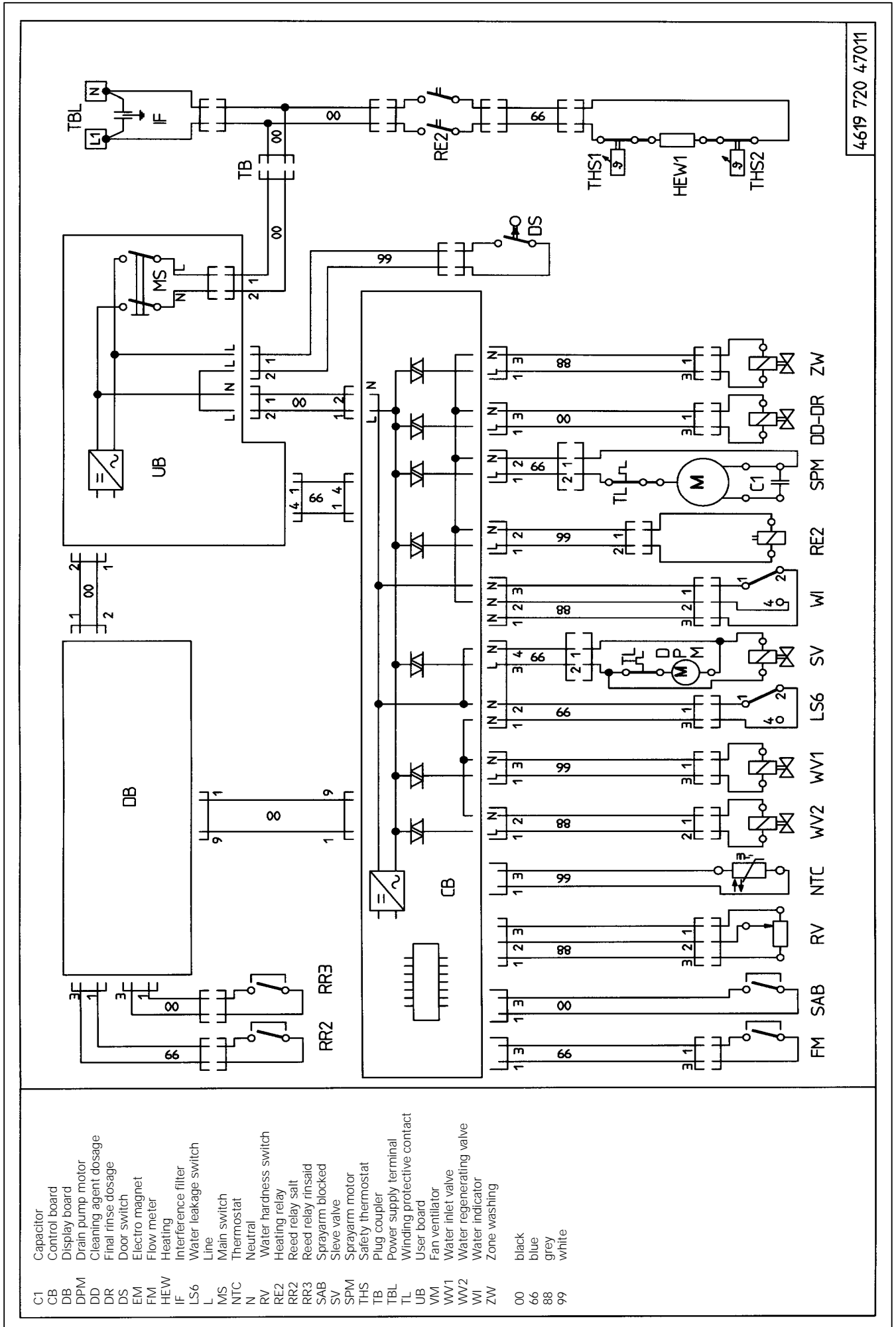

4619 720 47011

**Program diagram**

- no program function
  - contact or triac closed
- FM... amount of water  
t2 heating time up to temp.  
t3 draining time up to the water indicator is low

function of the machine

Start position for all Progr.

Start position for all Progr.	1	contacts										program table								
		VM	ZW	DD-DR	SPM	RE2	WI	SV	DPM	WV2	WV1	Prewash Program cold	Delicate Program 40° C	Rapid Program 50° C	BIO-ECO Program 50° C	Daily Program 65° C	Normal Program 65° C	Intensiprogram 70° C	Program Sequence LEDs	
draining	1																		PS1	
filling	2																			
draining	3																			
filling	4																			
draining	5																			
filling	6																			
draining	7																			
filling - rinsing	8																			
rinsing - heating	9																			
rinsing	10																			
rinsing - draining	11																			
filling - rinsing	12																			
rinsing - dos. detergent	13																			
rinsing - heating	14																			
rinsing	15																			
rinsing - heating	16																			
rinsing	17																			
rinsing - draining	18																			
filling - rinsing	19																			
rinsing	20																			
rinsing - draining	21																			
filling - rinsing	22																			
rinsing	23																			
rinsing - draining	24																			
filling - rinsing	25																			
rinsing - heating	26																			
rinsing - dos. rinse aid	27																			
rinsing	28																			
rinsing - dos. rinse aid	29																			
rinsing - heating	30																			
rinsing	31																			
draining	32																			
drying - without Fan	33																			
drying - regenerating	34																			
drying - regenerating - draining	35																			
drying - regenerating	36																			
drying - regenerating - filling	37																			
drying - regenerating	38																			
drying - regenerating - filling	39																			
drying - draining	40																			
drying	41																			
drying - draining	42																			
End	43																		PS4	

		contacts										LEDs							
		VM	ZW	DD-DR	SPM	RE2	WI	SV	DPM	WV2	WV1	PS1	PS2	PS3	PS4	ZW			
draining	1																		
filling	2																		
draining	3																		
filling	4																		
draining	5																		
filling	6																		
draining	7																		
filling - rinsing	8																		
pause - dos. detergent	9																		
rinsing - heating	10																		
regenerating	11																		
regenerating - draining	12																		
drying-regenerating-draining	13																		
End	14																		

## Text/Legend

**Test procedure for SERVICE-TEST-PROGRAM DOLPHIN dishwashers**

1. Start the test program.  
If there is a defective component indicated, open the plinth and take out the control board.
2. Check the component.  
Unplug the indicated component from the control board and check it by using an Ohm-measure equipment.  
If the ohms are correct, check the cables to the component and check the component itself.
3. Check the control board.
4. Only if there is no reaction when pushing a push button or turning the rotary switch, then test with the test points.
5. At the end of the repair start the test program again to see that the failure is solved.

More details: s. chapter test program for service.

**Attention:**

First unplug the appliance, then set the connection clamps of the volt measurement on the test points.

Danger for short circuit.

More details see chapter test point.

Short circuits on components can damage the control board.

If electronic boards are wet, do not switch the appliance on.

The failures F1 NTC break

F2 water leakage

F9 continuous water inlet

are checked and indicated immediately after start of the program.

Therefore these failures have to be solved before starting the test program.

When these failures are not solved, the test program does not run.

The electrical components get their voltage via triac from the control board. For testing the volume of voltage the volt meter must be parallel to the component (the component must be plugged on). If the component is plugged off, then on the plug the measured voltage is reduced.

**Indication of failure and alarms**

Whirlpool and Ignis appliances

failure	failure no.	indication	indication within test program
NTC - break	F1	start LED flashes	PS1 flashes
water leakage failure	F2	start LED flashes	PS2 flashes
heating system failure	F3	start LED flashes	PS3 flashes
draining failure	F4	start LED flashes	PS4 flashes
spray arm blocked	F5	PS1 flashes	PS1 + PS4 flash
water tap closed	F6	start LED flashes	PS2 + PS4 flash
flow meter failure	F7	start LED flashes	PS3 + PS4 flash
water level failure	F8	start LED flashes	PS2 + PS3 flash
water inlet continuously on	F9	start LED flashes	PS1 + PS3 flash
salt		alarm LED on	alarm LED on
rinse agent		alarm LED on	alarm LED on

**Passive test program**

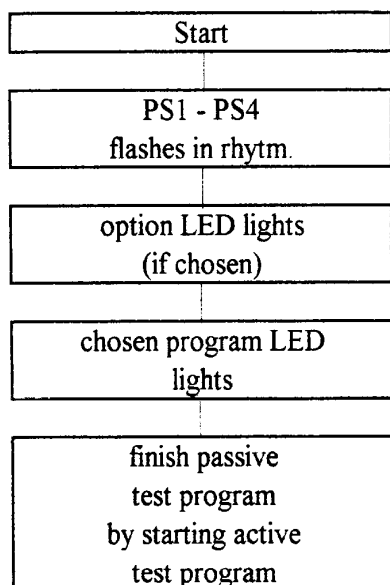

The passive test program shows the stored failure.  
 If there is no failure the passive test program runs normal.

**Start procedure**

1. Switch off the appliance
2. Push start button and hold it and select program BIO-ECO 50 °C (d)
3. Finish pushing the start button when the start LED flashes
4. Failure indication

**Program sequence LED**

PS1	1. LED	backrinsing prewash
PS2	2. LED	mainwash intermediate rinse final rinse
PS3	3. LED	drying
PS4	4. LED end	goes off if any button is pushed; goes off after 30 min. progr. is finished

**Indication of failure and alarms**

Bauknecht appliances low and high version

failure	failure no.	indication without digits	indication with digits	indication within test program
NTC - break	F1	start LED flashes	F1 at digits	PS1 flashes F1 at digits
water leakage failure	F2	start LED flashes and alarm LED	alarm LED flashes	PS2 flashes F2 at digits
heating system failure	F3	start LED flashes	F3 at digits	PS3 flashes F3 at digits
draining failure	F4	start LED flashes	F4 at digits	PS4 flashes F4 at digits
spray arm blocked	F5	PS1 flashes	alarm LED flashes	PS1 + PS4 flash F5 at digits
water tap closed	F6	start LED flashes	alarm LED flashes	PS2 + PS4 flash F6 at digits
flow meter failure	F7	start LED flashes	F7 at digits	PS3 + PS4 flash F7 at digits
water level failure	F8	start LED flashes	F8 at digits	PS2 + PS3 flash F8 at digits
water inlet continuously on	F9	start LED flashes	alarm LED flashes (water leakage)	PS1 + PS3 flash F2 at digits
salt		alarm LED on	alarm LED on	alarm LED on
rinse agent		alarm LED on	alarm LED on	alarm LED on

With the passive test program all LEDs and buttons can be tested.

**Passive test program**

If there is no failure, the passive test program runs normal.

**Start procedure**

Start

**ROTARY VERSION**

1. Switch off the appliance
2. Select program BIO/ECO (d)
3. Push start button and hold it and switch on the main switch
4. When start LED flashes, then release start button

**PUSH BUTTON VERSION**

1. Switch off the appliance
2. Push start button hold it and switch on the main switch
3. Release the start button when the start LED flashes
4. Select program BIO/ECO (d)

PS1 - PS4 flashes in rhythm.

option LED lights (if chosen)

chosen program LED lights

finish passive test program by starting active test program

**Program sequence LED**

PS1	1. LED	backrinsing prewash
PS2	2. LED	main wash intermediate rinse final rinse
PS3	3. LED	drying
PS4	4. LED end	goes off if any button is pushed
		goes off after 30 min. progr. is fin.

**Active test program**

All appliances Bauknecht, Whirlpool and Ignis

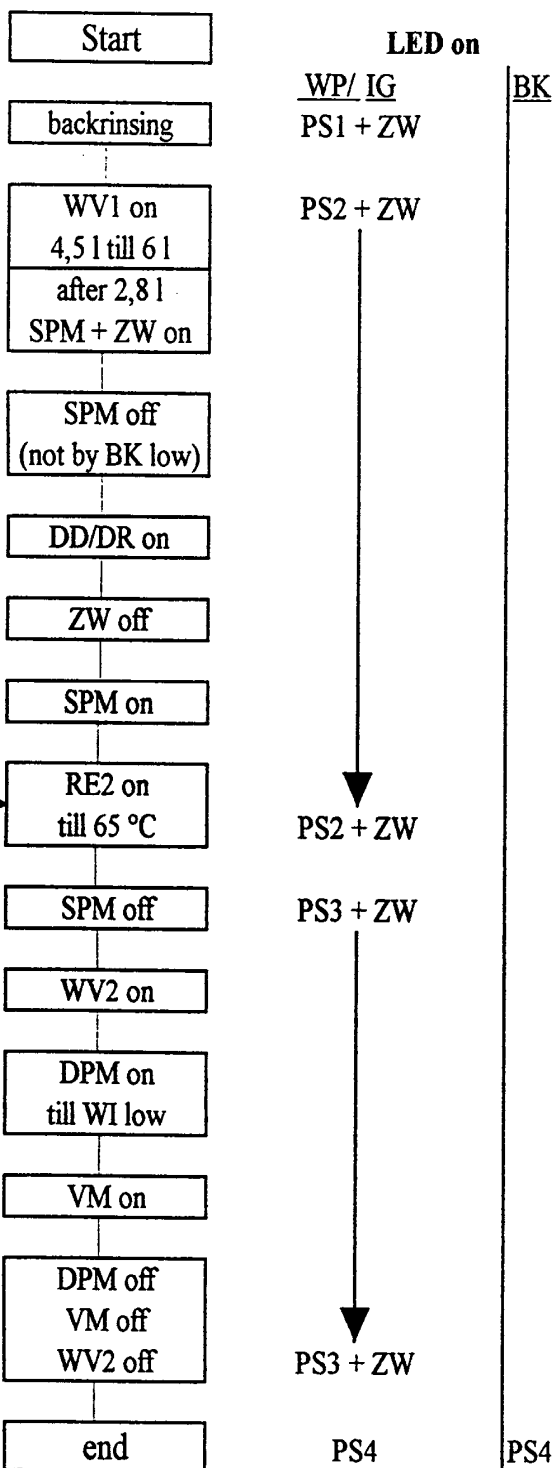

only on this step  
 can be jumped  
 to the next step  
 by short pushing  
 the start button  
 again

**Test procedure**

1. passive test program O. K.?
  - no: repair failure
  - yes: push start button shorter than 3 sec.
2. active test program starts

**Remarks**

The active test program runs to the failure position and stops or, if there is no failure, to the end.

The failure position is indicated:  
 On WP and IG appliances by switching off the flashing start LED.  
 On BK appliances the flashing start LED lights continuously.

To leave the test progr. push start button for longer than 3 sec.

Too less salt or too less rinse aid leads not to the stop of the appliance.

The function of the zone wash valve can only be checked optically.  
 A defect leads to an instable SPM pressure.

The function of the sieve valve can only be checked optically.  
 In case of defect the housing of the selfcleaning microfilter is not empty on the end of the program.

Appliances which have no program sequence LED/digits cannot show the failure.  
 On these appliances the failure can only be found by starting the test program and following this by using the program chart.  
 The steps of the test program are as normal.

**Handling of failures****F1. NTC break**

- temperature out of the normal value ( -10 degr. till +85 degr. C)

**Possible failures**

- heating higher than +85 degr. C
- NTC defective
- dishwasher is frozen, less than -10 degr. C

**F2. water leakage**

- water is in the drip tray floater (LS6) switches off the WV1 and the electronic switches on the DPM till WI reports empty

**F3. heating system defective**

- too less heating speed (lower 1,5 degr. in 3 min.)
- heating (HEW) defective
- relais (RE2) defective

**F4. draining failure**

drain pump starts and after 4 min. the WI detects not empty

- drain pump (DPM) defective
- syphon closed
- control board (CB) defective
- water indicator (WI) defective (is switched on)

**F5. spray arm blocked (leads not to stop the appliance)**

SAB sensor sends less than 10 impulses/min.

- spray arm blocked or not fixed well
- selfcleaning microfilter blocked
- spray pump (SPM) does not work well
- SAB sensor defective

**F6. water tap closed**

water valve (WV1) is switched on but flow meter (FM) sends no impulses (less than 10 imp. in 10 sec.) and the water indicator (WI) is at low level

- water tap closed
- water inlet hose blocked
- water inlet valve (WV1) defective
- flow meter (FM) defective (leads to FM failure)

**F7. flow meter failure**

water inlet valve is switched on and the water indicator (WI) is switched on high level

- flow meter (FM) sends to less impulses (less than 10 imp. in 10 sec.)
- water tap closed
- water inlet hose blocked
- water inlet valve (WV1) defective
- flow meter (FM) defective
- water indicator (WI) is defective

**F8. water level failure**

failure monitored during spray pump is on and the water indicator switches back more than 10 times in 2 min.

- water indicator defective
- sieve blocked
- water strongly foams
- pot has turned off and is filled with spray water
- no stable spray pump (SPM) working

**F9. continuous water inlet**

water inlet valve (WV1) is switched off, water indicator (WI) on, flow meter (FM) sends impulses more than 10 imp. in 10 sec.

- water inlet valve (WV1) mechanically not closed
- triac (CB) for WV1 is closed

reaction: interval 30 sec. draining / 20 sec. tracing

For salt, rinse aid, zone wash valve, sieve valve failure see active test program.



			Programs												
BK	IG	WP	a	b	c	d B K	d W I	e B K	e W I	f	g	h	i	j	k
A3			X			X				X					
	A3	A3	X				X			X					
A4			X			X		X		X					
	A4	A4	X				X		X	X					
	A5	A5	X				X		X	X	X				
	A6	A6	X		X		X		X	X	X				
	A7		X	X	X		X		X	X	X				
B4			X			X		X		X					
B5			X			X		X		X	X				
		B5	X				X		X	X	X				
B6			X		X	X		X		X	X				
		B6	X		X		X		X	X	X				
		B7	X	X	X		X		X	X	X				
C5			X			X		X		X	X				
C6			X		X	X		X		X	X				
C7			X	X	X	X		X		X	X				
C11			X	X	X	X		X		X	X	X	X	X	X

- a prewash
- b glass 40 degr.
- c rapid 50 degr.
- d bio eco 50 degr.(BK without pre wash,WH IG with pre wash)
- e bio normal 50 degr.(BK with pre wash cold)
- e daily 65 degr.(only IG WH, without pre wash)
- f normal 65 degr.(with prewash cold)
- g intensive 70 degr.(with prewash 40 degr.)
- h -d- bio eco 50 degr.(BK without pre wash),+ e-button
- i -e- bio normal 50 degr.(BK with pre wash cold) + e-button
- j -f- normal 65 degr.(with prewash cold) + e-button
- k -g- intensive 70 degr.(with prewash 40 degr.) + e-button

After starting a program this program is locked. That means neither by unplugging / switching of the appliance nor by setting an other program, the first setted program can be changed. Chancing of the program is only possible by pushing the start-button again for longer than 3 sec.

On appliances with seperate On-Off button the last used program is stored. That means if the customer wants to use the same program again he has only to press the on-button and the start-button.

## Test points on the control board for Whirlpool and Ignis appliances

With these test points the function of the buttons and the rotary switch can be checked. The test points are in the service window on the control board.

For the test fine clamps, cables and volt meter with high input resistance are necessary.

**Before setting the clamps on the test points, switch off the appliance.**

Test points: T0 = common line    T2 = analogue value  
 T1 = analogue value    T3 = digital signal

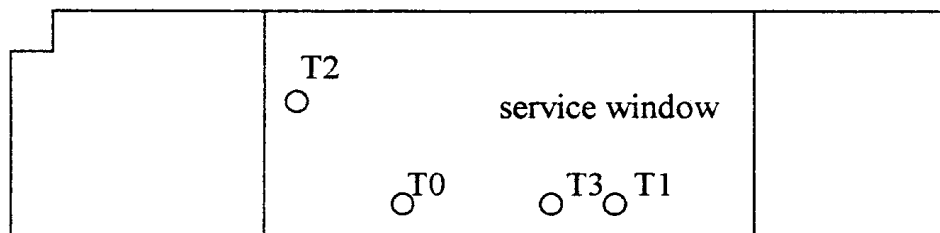

control board

### Check: test point T0 to T1

Communication between Control board and Display board

pushed button	voltage	from	to
all off	appr. -6,19 V (DC)	control board	display board
ZW	appr. -3,69 V (DC)	display board	control board
delay start	appr. -2,33 V (DC)	display board	control board
ZW + delay start	appr. -1,85 V (DC)	display board	control board

### Check: test point T0 to T2

Communication between Control board and User board

rotary switch	voltage	from	to
progr. a	appr. -1,54 V (DC)	user board	control board
progr. b	appr. -2,06 V (DC)	user board	control board
progr. c	appr. -2,57 V (DC)	user board	control board
progr. d	appr. -3,42 V (DC)	user board	control board
progr. e	appr. -3,96 V (DC)	user board	control board
progr. f	appr. -4,47 V (DC)	user board	control board
progr. g	appr. -5,00 V (DC)	user board	control board
start button	appr. 0,00 V (DC)	user board	control board

### Check: test point T0 to T3

Communication between Control board and Display Board

multiplexing                      appr. -3,18 V (DC)

How exact the data are, depends on the measure equipment.

## Test points on the control board for Bauknecht appliances

With these test points the function of the buttons and the rotary switch can be checked. The test points are in the service window on the control board.

For the test fine clamps, cables and volt meter with high input resistance are necessary.

**Before setting the clamps on the test points, switch off the appliance.**

Test points: T0 = common line      T2 = analogue value      T3 high = serial link  
T3 low = digital signal

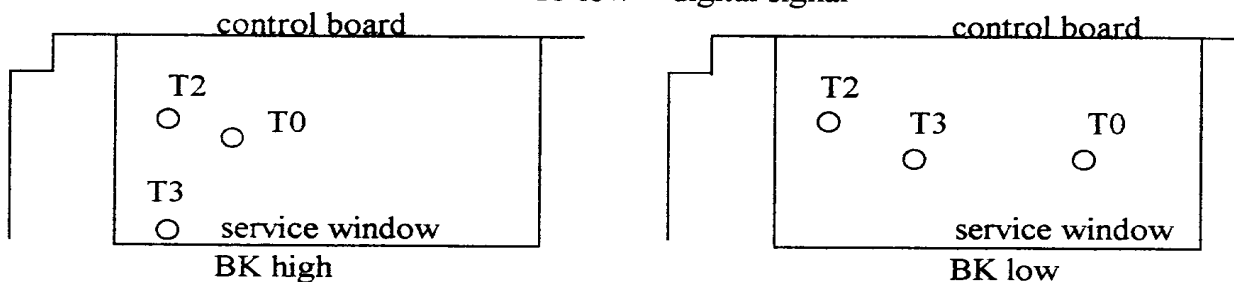

### Check: test point T0 to T2 high range (see control board: BK-CB -H)

Communication between Control board and User board or Control- and Display board

pushed button or rotary switch	voltage	from	to
off	appr. -5,0 V (DC)	control board	user board
progr. a	appr. -1,0 V (DC)	user board	control board
progr. b	appr. -1,5 V (DC)	user board	control board
progr. c	appr. -2,0 V (DC)	user board	control board
progr. d (h)	appr. -2,5 V (DC)	user board	control board
progr. e (i)	appr. -3,0 V (DC)	user board	control board
progr. f (j)	appr. -3,5 V (DC)	user board	control board
progr. g (k)	appr. -4,0 V (DC)	user board	control board
start button	appr. -0,6 V (DC)	user board	control board
option- , gentle- or delay button	appr. -5,0 V (DC)	control board	display board

### Check: test point T0 to T2 low range (see control board: BK-CB -L)

Communication between Control board and User board or Control- and Display board

pushed button or rotary switch	voltage	from	to
off	appr. -5,0 V (DC)	control board	user board
progr. a	appr. -1,0 V (DC)	user board	control board
progr. b	do not exist on low range		
progr. c	appr. -1,5 V (DC)	user board	control board
progr. d	appr. -2,0 V (DC)	user board	control board
progr. e	appr. -2,5 V (DC)	user board	control board
progr. f	appr. -3,0 V (DC)	user board	control board
progr. g	appr. -3,5 V (DC)	user board	control board
start button	appr. -0,6 V (DC)	user board	control board
eco-dry button	appr. -4,0 V (DC)	control board	display board
delay button	appr. -4,5 V (DC)	control board	display board

### Check: test point T0 to T3 high range

no program running	-0,8/-1,0 V (DC)	control board	display board
program bio/eco running	-0,3/-0,8 V (DC)	control board	display board

### Check: test point T0 to T3 low range

multiplex signal	-2,5 V (DC)	control board	display board
------------------	-------------	---------------	---------------

How exact the data are, depends on the measure equipment.